

量具产品

MEASURING TOOLS

GENERTEC HMCT is one of the largest precision measuring and cutting tool manufacturers in China, it is also an ISO 9001 quality system certified enterprise.

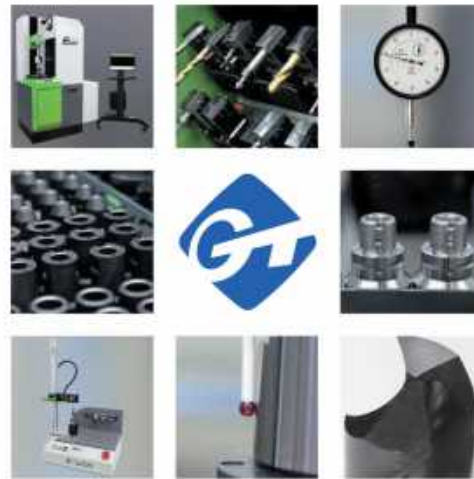

<http://www.links-china.com>

期待您的关注



通用技术集团哈尔滨量具刃具有限责任公司
GENERTEC HARBIN MEASURING & CUTTING TOOL CO., LTD.

地址：哈尔滨市香坊区和平路44号 Add: NO.44 HePing Road Harbin China

电话 (Tel) : 400-008-1952

产品请以实物为准，照片仅供参考，最终解释权归通用技术哈量公司所有

HLYB2303



SINCE1952

www.links-china.com

诚信经营 信誉第一

Integrity management, Reputation first

We're sincere ...

“诚实守信”作为通用技术哈量公司员工素质训的重要内容，已化为企业的行为方式和员工的自觉行动贯穿于生产经营活动的全过程，企业一直坚持“以顾客满意为宗旨，以产品零缺陷为目标”的质量方针，不断创造着顾客满意的产品与服务。顾客的信赖是哈量创新发展的源泉和动力，哈量将以“进取在每一天”的企业精神，用先进的技术、优质的产品、真诚的服务回报我们的顾客。

As the important content of GENERTEC HMCT staff quality training, “Honest and Trustworthy” has been integrated into enterprise manners and staff conscious actions through the whole production and business activities. Enterprise maintains “Null defect of products as our goal and satisfaction of customers as our object” as the quality principal, and continuous create satisfied products and services for customers. Trust of customer is the source and power for innovation and development of GENERTEC HMCT. GENERTEC HMCT will keep the enterprise spirit “make a progress everyday” and repay customers with advanced technology, high-quality products and sincere service.



Enterprise Honor



专业优势 创新发展

Professional advantage, Innovative development

We're making innovations...



伴随着共和国成长脚步，通用技术哈量公司经过七十年的创新发展，其专业的研发水平、加工能力、生产规模及产品质量达到了同行业领先水平，连环牌产品以其雄厚的品牌实力和品质畅销全国及欧洲等 30 多个国家和地区，深受用户的信赖和好评。

进入二十一世纪以来，哈量秉承“追求完美，永创一流”的企业理念，坚持走科学发展之路，增强自主创新能力，加快产品结构调整，合作推进产业链创新多赢，为推动我国机床工具行业的发展做出了贡献，为建设成为中国一流、国际领先的科技型工量具专业制造企业而努力奋斗！

Along with the growth of PRC, GENERTEC HMCT experiences 70 years of innovative development, the professional research and development level, processing ability, production scale and products quality have reached advanced level of same industry. With strong brand strength and excellent quality, LINKS products are well sold to more than 30 countries and areas all over domestic and abroad markets, and earns user's trust and good comments.

In the 21st century, GENERTEC HMCT follows the enterprise concept "pursue perfection, to be the best forever", sticks to the road of scientific development, enhances self-innovation, accelerates adjustment of products structure, cooperates and forwards innovation multi-win of industrial chain to make contributions for the development of our machine tooling industry, and to make arduous efforts to be a domestic first-class and international leading technology-based professional manufacturing enterprise of measuring tools.



目 录 CONTENTS

卡尺 CALIPERS

游标卡尺 601.....1	Vernier Calipers 601.....1
游标卡尺 602.....2	Vernier Calipers 602.....2
游标卡尺 603A.....3	Vernier Calipers 603A.....3
游标卡尺 603B.....4	Vernier Calipers 603B.....4
带表卡尺 604.....5	Dial Calipers 604.....5
电子数显卡尺 605.....7	Digital Calipers 605.....7
电子数显卡尺 605B.....8	Digital Calipers 605B.....8
无线数显卡尺 605C.....9	Wireless Digital Calipers 605C.....9
绝对原点数显卡尺 605D.....10	Absolute Origin Caliper 605B.....10
IP67 防水数显卡尺 605E.....11	IP67 Waterproofing Digital Caliper 605E.....11
深度游标卡尺 606.....12	Depth Vernier Gauges 606.....12
带表深度卡尺 616.....13	Dial Depth Gauges 616.....13
电子数显深度卡尺 615.....14	Electronic Digital Depth Gauges 615.....14
高度游标卡尺 609.....15	Height Vernier Gauges 609.....15
带表高度卡尺 617.....16	Dial Height Gauges 617.....16
电子数显高度卡尺 611.....17	Electronic Digital Height Gauges 611.....17
万能角度尺 613.....18	Universal Bevel Protractors 613.....18

千分尺 MICROMETERS

外径千分尺 701.....19	Outside Micrometer 701.....19
外径千分尺 702.....20	Outside Micrometer 702.....20
外径千分尺 703B.....21	Outside Micrometer 703B.....21
外径千分尺(管结构) 704 705.....22	Outside Micrometers(Tube Structure)704 705.....22
数显外径千分尺 704A.....23	Digital Display Outside Micrometer 704A.....23
数显外径千分尺 704B.....24	Digital Display Outside Micrometer 704B.....24
测微头 706.....25	Micrometer Heads 706.....25



目 录 CONTENTS

内径千分尺 707 708 709.....	26	Inside Micrometers 707 708 709.....	26
螺纹千分尺 711.....	27	Thread Micrometer 711.....	27
数显螺纹千分尺 711A.....	28	Digital Display Thread Micrometer 711A.....	28
公法线千分尺 712.....	29	Gear Tooth Micrometer 712.....	29
深度千分尺 713.....	30	Depth Micrometers 713.....	30
数显深度千分尺 713A.....	31	Digital Display Depth Micrometer 713A.....	31
壁厚千分尺 719.....	32	Wall Thickness Micrometer 719.....	32
板厚千分尺 724.....	33	Plate Micrometer 724.....	33
杠杆千分尺 725.....	34	Indicating Micrometer 725.....	34
尖头千分尺 728 728B.....	35	Point Micrometer 728 728B.....	35
数显尖头千分尺 728A.....	36	Digital Display Pointed Micrometer 728A.....	36
小测头千分尺 729.....	37	Small Probe Micrometer 729.....	37
三爪内径千分尺 732.....	38	Internal Micrometers With Three-Point Contact 732.....	38
数显三爪内径千分尺 732A.....	39	Digital Display Internal Micrometers With Three-Point Contact 732A.....	39
内测千分尺 733.....	40	Inside Micrometer 733.....	40
数显内测千分尺 733A.....	41	Digital Display Inside Micrometer 733A.....	41
叶片千分尺 734.....	42	Blade Micrometer 734.....	42
数显叶片千分尺 734A.....	43	Digital Blade Micrometer 734A.....	43

指示表 INDICATORS

百分表 / 千分表 801 802 803.....	44	Dial Indicators 801 802 803.....	44
杠杆百分表 804/ 杠杆千分表 805.....	45	Dial Test Indicators 804/805.....	45
数显指示表 806(IV型).....	46	Electronic Digital Indicators Type 806(IV).....	46
数显指示表 806(V型).....	47	Electronic Digital Indicators Type 806(V).....	47
内径百分表 808 809.....	48	Bore Measuring Indicators 808 809.....	48
内径千分表 810 811.....	49	Bore Measuring Indicators 810 811.....	49
扭簧比较仪 812 813 814.....	50	Microcomparators 812 813 814.....	50
百分比较仪 / 千分比较仪 816.....	51	0.01mm Comparators And 0.001mm Comparators 816.....	51



目 录 CONTENTS

双面百分表 818.....	52	Double-sided 0.01mm Dial Indicators 818.....	52
深度百分表 819.....	53	Depth Dial Indicators 819.....	53
磁性表座 822.....	54	Magnetic Bases For Dial Indicators 822.....	54
测厚规 823.....	55	Thickness Gauges 823.....	55
测厚规 823A.....	56	Thickness Gauges 823A.....	56
公制带表外卡规 824.....	57	Metric Outside Dial Caliper Gauges 824.....	57
公制带表外卡规 824A.....	58	Metric Outside Dial Caliper Gauges 824A.....	58
公制带表内卡规 825.....	59	Metric Outside Dial Caliper Gauges 825.....	59
公制带表内卡规 825A.....	60	Metric Outside Dial Caliper Gauges 825A.....	60

量块 GAUGE BLOCKS

量块 901 902.....	61	Gauge Blocks 901 902.....	61
千分尺检定专用量块 903.....	64	Special Gauge Blocks For Testing Micrometers 903.....	64
游标卡尺检定专用量块 904.....	65	Special Gauge Blocks For Testing Vernier Calipers 904.....	65
数显卡尺检定专用量块 905.....	66	Special Gauge Blocks For Testing Digital Calipers 905.....	66
角度量块 906.....	67	Angle Gauge Blocks 906.....	67
刀口尺 909.....	68	Straight Edges 909.....	68
宽座角尺 910.....	69	Wide-Base Angle Squares 910.....	69
量块夹子 911.....	70	Gauge Block Clips 911.....	70

量规 GAUGES

螺纹测量用三针 921.....	71	Three Wires For Thread Checking 921.....	71
针规 922.....	74	Pin Gauges 922.....	74
普通螺纹量规 923 924.....	75	Common Thread Gauges 923 924.....	75
美标统一螺纹量规 925 926.....	78	Ansi Standard Thread Gauges 925 926.....	78
莫氏圆锥量规 927 928.....	81	Morse Taper Gauges 927 928.....	81
莫氏圆锥量规 929 930.....	82	Morse Taper Gauges 929 930.....	82



目 录 CONTENTS

光滑极限塞规 933.....	83	Plain Limit Plug Gauges Type 933.....	83
对表环规 934.....	85	Plain Ring Gauges 934.....	85
抽油泵螺纹量规 935 936.....	86	Thread Gauges For Oil Sucking Pumps 935 936.....	86
55°非密封管螺纹量规 937 938.....	87	Non-Sealing Pipe Threads With 55 Degree Thread Angle 937 938.....	87
梯形螺纹量规 939 940.....	88	Trapezoidal Thread Gauges 939 940.....	88
抽油杆量规 941.....	90	Sucker Rod Gauge 941.....	90
抽油杆量规 942.....	91	Sucker Rod Gauge 942.....	91
60°锥管螺纹量规 943 944.....	92	60 ° Taper Pipe Thread Gauges 943 944.....	92
用螺纹密封的管螺纹量规 945 946.....	93	Gauges For Pipe Threads Where Pressure-Tight Joints Are Made On The Threads 945 946.....	93
气瓶专用螺纹量规 947 948.....	94	Special Thread Gauge For Gas Cylinders 947 948.....	94
美制干密封管螺纹量规 949 950.....	95	US-System Dry Seal Pipe Thread Gauge 949 950.....	95
组合式表面粗糙度比较样块 951.....	96	Multi-Pattern Surface Roughness Comparison Specimens 951.....	96
单组合式表面粗糙度比较样块 952.....	97	Single-Pattern Surface Roughness Comparison Specimens 952.....	97



游标卡尺 601

Vernier Calipers 601

- 采用优质碳钢或不锈钢制造
 - 可测量内、外尺寸、深度及台阶等
 - 主尺、尺框刻线面无光镀铬
 - 主尺、尺框整体热处理，测量面淬硬
 - 符合 GB 标准
- Made of high quality carbon steel or stainless steel.
 - They are used to measure outside, inside dimensions, depth and step.
 - The main scale and the vernier are satin chromed.
 - The beam and the vernier are entirely heat-treated and all the measuring faces are specially hardened.
 - It conforms to GB standard.

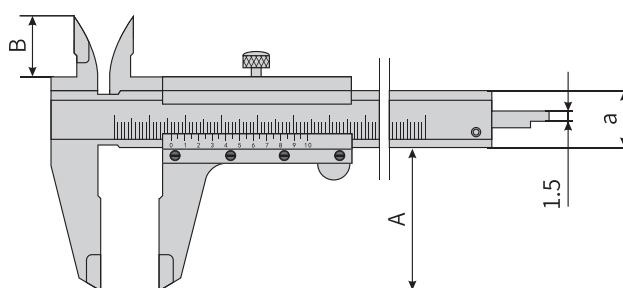
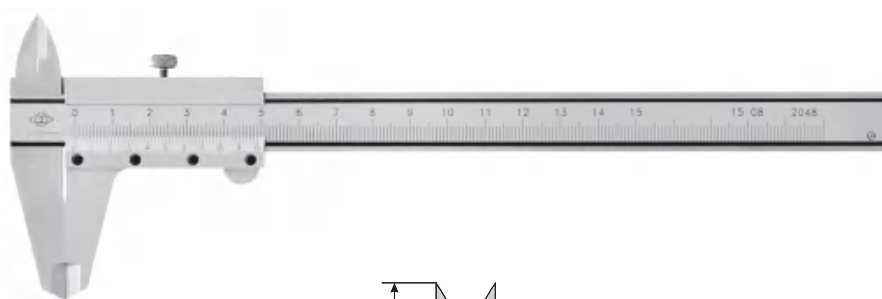

单位 (Unit) : mm

编号 Item No.	测量范围 Measuring Range	分度值 Graduation Value	示值误差 Indication Error	a	A	B	质量 Weight(kg)	备注 Remarks
601-01/01S	0-150	0.02	±0.03	16	40	17	0.149	碳钢 / 不锈钢 II型
601-02/02S	0-200	0.02	±0.03	17	60	38	0.304	碳钢 / 不锈钢 II型
601-03/03S	0-300	0.02	±0.04	17	60	38	0.355	碳钢 / 不锈钢 II型

订货说明: 按产品对应的编号订货。例: 601-01 为碳钢卡尺, 601-01S 为不锈钢卡尺。

Order Description: order according to the number of products. Note: S Material is stainless steel.



游标卡尺 602

Vernier Calipers 602

- 采用优质碳钢制造
- 可用于内尺寸、外尺寸测量以及划线
- 主尺、尺框刻线面无光镀铬
- 主尺、尺框整体热处理，测量面淬硬
- 符合 GB 标准
- Made of high quality carbon steel.
- They are used to measure outside, inside dimensions and scribing in machining.
- The main scale and the vernier are satin chromed.
- The beam and the vernier are entirely heat-treated, and all the measuring faces are specially hardened.
- It conforms to GB standard.

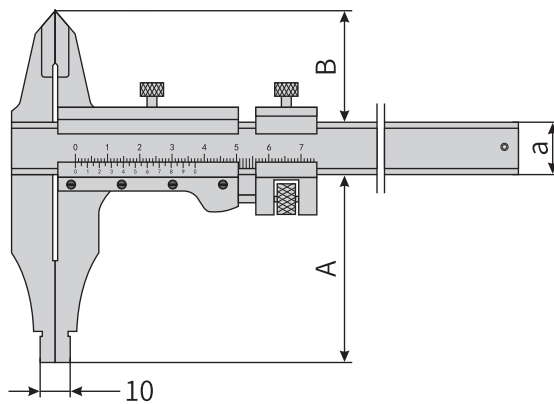
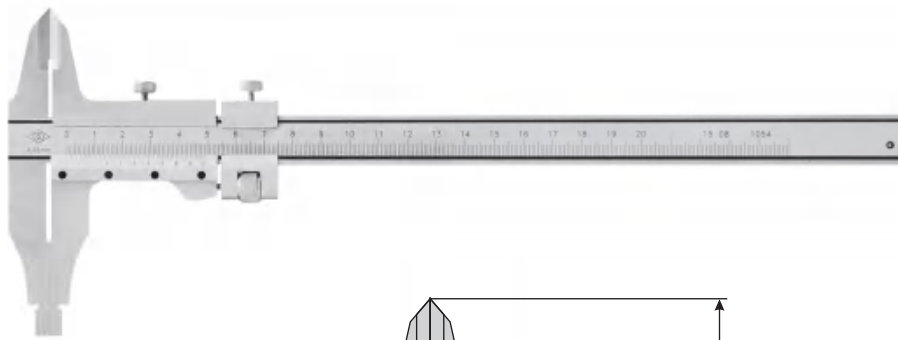

单位 (Unit) : mm

编号 Item No.	测量范围 Measuring Range	分度值 Graduation Value	示值误差 Indication Error	a	A	B	质量 Weight(kg)	备注 Remarks
602-02	0-200	0.02	±0.03	17	60	38	0.304	碳钢III型
602-03	0-300	0.02	±0.04	17	60	38	0.355	碳钢III型

订货说明：按产品对应的编号订货。

Order Description: order according to the number of products.



游标卡尺 603A

Vernier Calipers 603A

- 采用优质碳素钢制造
- 可用于内尺寸、外尺寸测量
- 符合 GB 标准
- Made of high-quality carbon steel .
- They are used to measure outside, inside dimensions.
- It conforms to GB standard.

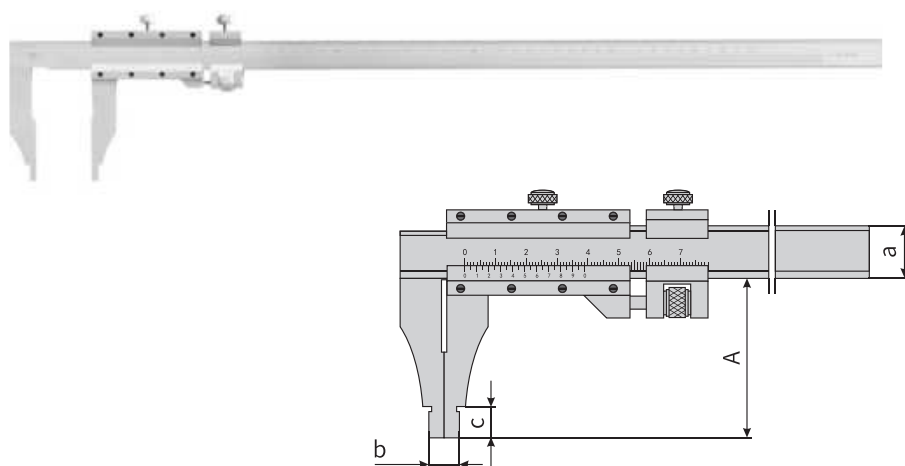

单位 (Unit) : mm

编号 Item No.	测量范围 Measuring Range	分度值 Graduation Value	示值误差 Indication Error	A	b	c	a	质量 Weight(kg)	备注 Remarks
603A-01	0-500	0.02	±0.05	80	10	12	21	0.75	IV型
603A-03	0-600	0.02	±0.06	80	10	12	21	0.95	IV型
603A-05	0-1000	0.02	±0.07	100	20	18	32	2.60	IV型
603A-07	0-1500	0.02/0.05	±0.11/±0.16	150	20	20	40	6.61	IV型
603A-08	0-2000	0.02/0.05	±0.14/±0.20	200	30	20	48	8.90	IV型
603A-10	0-3000	0.05	±0.31	260	40	35	76	25.0	IV型
603A-11	0-4000	0.05	±0.40	260	40	35	76	29.46	IV型 ★
603A-12	0-5000	0.05	±0.55	260	40	35	76	35.2	IV型 ★ ▲

注： ★ 为特殊订货 ▲ 为企业标准

Note: ★ For a special order ▲ For enterprise standards



游标卡尺 603B

Vernier Calipers 603B

- 采用优质不锈钢制造
- 可用于内尺寸、外尺寸测量
- 符合 GB 标准
- Made of high quality stainless steel.
- They are used to measure outside, inside dimensions.
- It conforms to GB standard.

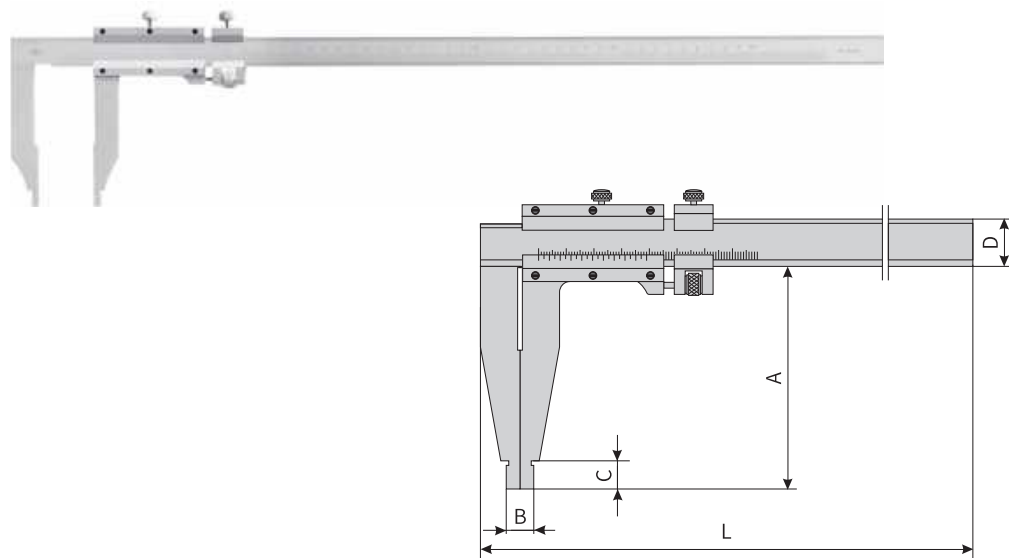

单位 (Unit) : mm

编号 Item No.	测量范围 Measuring Range	分度值 Graduation Value	示值误差 Indication Error	L	A	B	C	D	质量 Weight(kg)	备注 Remarks
603B-01	0-500	0.02	±0.05	660	100	10	12	25	1.2	IV型
603B-03	0-600	0.02	±0.06	760	100	10	12	25	1.3	IV型
603B-05	0-1000	0.02	±0.07	1200	125	20	18	32	3.1	IV型
603B-07	0-1500	0.02/0.05	±0.11/±0.16	1790	200	20	20	41.5	6.4	IV型
603B-08	0-2000	0.02/0.05	±0.14/±0.20	2300	200	20	20	41.5	8.0	IV型
603B-10	0-3000	0.05	±0.31	3360	300	20	20	53	16.3	IV型

订货说明：按产品对应的编号订货。

Order Description: order according to the number of products.



带表卡尺 604

Dial Calipers 604

- 采用优质不锈钢制造
- 读数直观、清晰方便
- 尺刻线面无光镀铬
- 主尺、尺框整体热处理，测量面淬硬
- 符合 GB 标准
- Made of high quality stainless steel.
- Direct reading, easy to read.
- The main scale and the vernier are satin chromed.
- The beam and the slider are entirely heat-treated all the measuring faces are hardened.
- It conforms to GB standard.

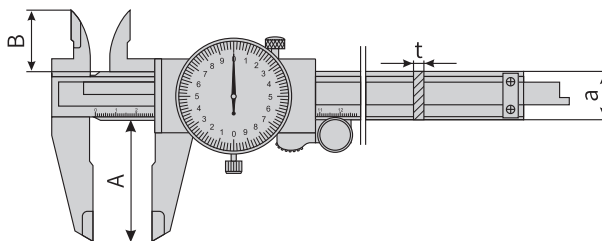

单位 (Unit) : mm

编号 Item No.	测量范围 Measuring Range	分度值 Graduation Value	示值误差 Indication Error	A	B	a	t	质量 Weight(kg)	备注 Remarks
604-01	0-150	0.02	±0.03	40	21	16	3.3	0.196	II型
604-02	0-200	0.02	±0.03	50	24.5	16	3.5	0.262	II型
604-03	0-300	0.02	±0.04	64	27.5	20	4	0.328	II型

订货说明：按产品对应的编号订货。

Order Description: order according to the number of products.



带表卡尺 604

Dial Calipers 604

- 采用优质不锈钢制造
- 读数直观、清晰方便
- 主尺刻线面无光镀铬
- 主尺、尺框整体热处理，测量面淬硬
- 符合 GB 标准
- Made of high quality stainless steel.
- Direct reading, easy to read.
- The main scale and the vernier are satin chromed.
- The beam and the slider are entirely heat-treated all the measuring faces are hardened.
- It conforms to GB standard.

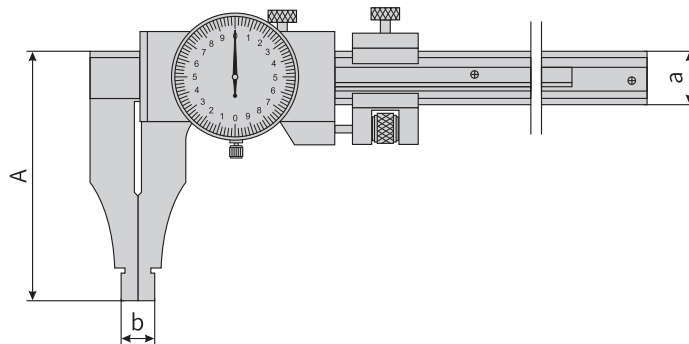

单位 (Unit) : mm

编号 Item No.	测量范围 Measuring Range	分度值 Graduation Value	示值误差 Indication Error	A	a	b	质量 Weight(kg)	备注 Remarks
604-04	0-500	0.02	±0.05	100	21	10	0.75	IV型 ★

注： ★ 为特殊订货。

Note: ★ For a special order.



电子数显卡尺 605

Digital Calipers 605

- 采用优质不锈钢制造
- 读数直观、清晰方便
- 具有公英制快速转换、任意位置置零等功能
- 主尺、尺框整体热处理，测量面淬硬
- 带数据输出
- 符合 GB 标准
- Made of high quality stainless steel.
- Big LCD displayer, easy to read.
- Fast switch-inch switch, zero setting at any position.
- The beam and the slider are entirely heat-treated all the measuring faces are hardened.
- Data output.
- It conforms to GB standard.

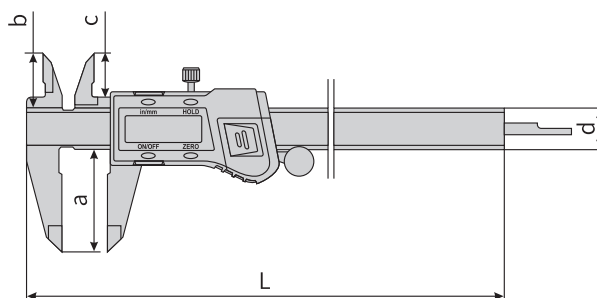

单位 (Unit) : mm

编号 Item No.	测量范围 Measuring Range	分辨力 Resolution	示值误差 Indication Error	L	a	b	c	d	质量 Weight(kg)	备注 Remarks
605-01	0-150	0.01	±0.03	236	40	21	16.5	16	0.20	金属壳II型
605-02	0-200	0.01	±0.03	286	50	24	19.5	16	0.21	金属壳II型
605-03	0-300	0.01	±0.04	400	60	26	21.5	16	0.30	金属壳II型

订货说明：按产品对应的编号订货。

Order Description: order according to the number of products.



电子数显卡尺 605B

Digital Calipers 605B

- 采用优质不锈钢制造
- 读数直观、清晰方便
- 具有公英制快速转换、任意位置置零等功能
- 主尺、尺框整体热处理，测量面淬硬
- 带数据输出
- 符合 GB 标准
- Made of high quality stainless steel.
- Big LCD display, easy to read.
- Fast switch-inch switch, zero setting at any position.
- The beam and the slider are entirely heat-treated all the measuring faces are hardened.
- Data output.
- It conforms to GB standard.

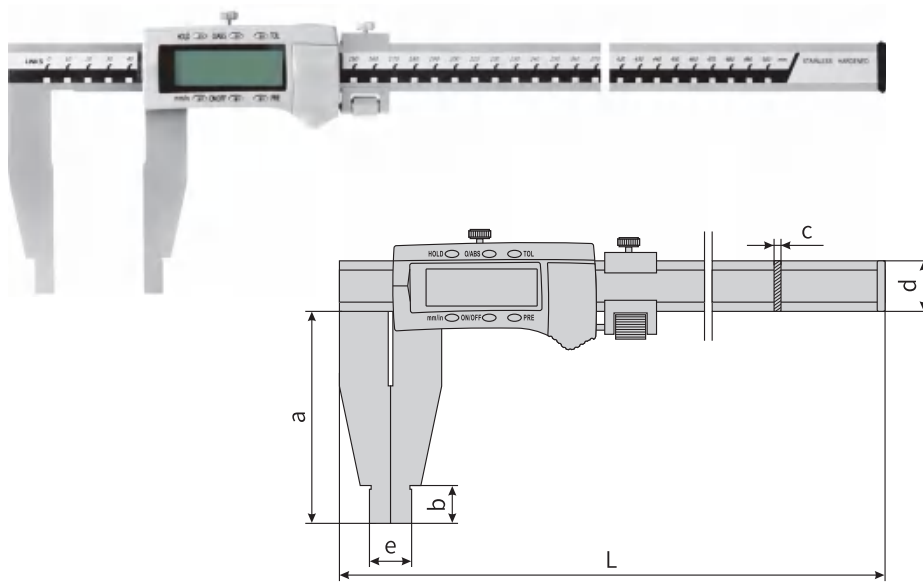

单位 (Unit) : mm

编号 Item No.	测量范围 Measuring Range	分辨力 Resolution	示值误差 Indication Error	L	a	b	c	d	e	质量 Weight(kg)	备注 Remarks
605B-01	0-500	0.01	±0.05	678	100	18	5.5	24	10	1.057	金属壳IV型
605B-02	0-1000	0.01	±0.07	1230	125	24	10.5	31	20	2.868	金属壳IV型
605B-03	0-1500	0.01	±0.11	1780	150	24	12.5	42	20	6.130	金属壳IV型
605B-04	0-2000	0.01	±0.14	2290	200	24	12.5	42	30	7.310	金属壳IV型

订货说明：按产品对应的编号订货。

Order Description: order according to the number of products.



无线数显卡尺 605C

Wireless Digital Calipers 605C

- 采用段码式液晶显示屏显示测量数据
 - 方便的操作按键，具有公英转换，测量数据保持等功能
 - 3V 锂电池供电，单尺可工作一年
 - 内置测量数据传输接口，可接有线或无线传输器
 - 可测量工件内径，外径，深度，台阶
 - 配备专用无线发射器，接收器，可实现智能组网测量
- The measurement data is displayed on a segment-coded LCD display.
 - Convenient operation buttons, with public data conversion, measurement data retention and other functions.
 - 3V lithium battery power supply, single foot can work for one year.
 - Built-in measurement data transmission interface, can be connected to wire or wireless transmitters.
 - It can measure the inner diameter, outer diameter, depth, and steps of the workpiece.
 - Equipped with dedicated wireless transmitters and receivers, it can realize intelligent networking measurement.

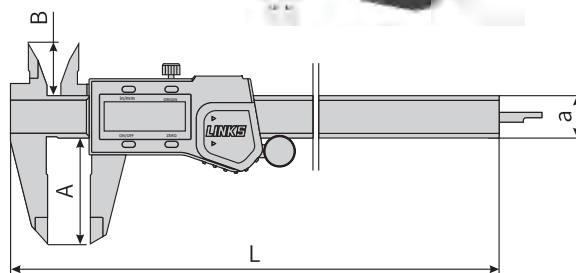

单位 (Unit) : mm

编号 Item No.	测量范围 Measuring Range	分辨力 Resolution	示值误差 Indication Error	L	A	B	a	质量 Weight(kg)	备注 Remarks
605C-01	0-150	0.01	±0.03	235.5	40	19.6	16	0.318	塑料壳II型

订货说明：按产品对应的编号订货。

Order Description: order according to the number of products.



绝对原点数显卡尺 605D

Absolute Origin Caliper 605D

- 采用优质不锈钢制造
- 测尺、尺框整体热处理，测量面淬硬
- 读数直观、测量方便
- 具有公英制快速转换、任意位置置零、绝对原点等功能
- 测尺、尺框移动速度不受限制
- 3V 锂电池，带数据输出
- 符合 GB 标准
- Made of high quality stainless steel.
- The ruler and ruler frame are heat treated as a whole, and the measuring surface is hardened.
- Intuitive readings and easy measurement.
- It has the functions of metric fast conversion, zero in any position, absolute origin and so on.
- The speed of the ruler and ruler frame is not limited.
- 3V copper battery with data output.
- It conforms to GB standard.

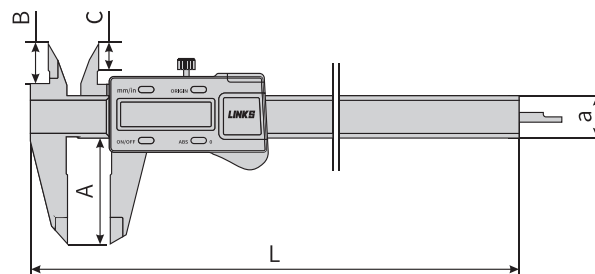

单位 (Unit) : mm

编号 Item No.	测量范围 Measuring Range	分辨力 Resolution	示值误差 Indication Error	L	A	B	C	a	质量 Weight(kg)	备注 Remarks
605D-01	0-150	0.01	±0.03	234	40	16	10.5	16	0.2	金属壳II型

订货说明：按产品对应的编号订货。

Order Description: order according to the number of products.



IP67 防水数显卡尺 605E

IP67 Waterproofing Digital Caliper 605E

- 采用优质不锈钢制造
- 读数直观、清晰方便
- 具有公英制快速转换、任意位置置零等功能
- 防水、防油、抗电磁干扰，防护等级达 IP67
- 符合 GB 标准
- Made of high quality stainless steel.
- Big LCD displayer, easy to read.
- Fast switch-inch switch, zero setting at any position.
- Waterproof, oil -proof, anti -electromagnetic interference, achieve to the IP67 protection level.
- It conforms to GB standard.

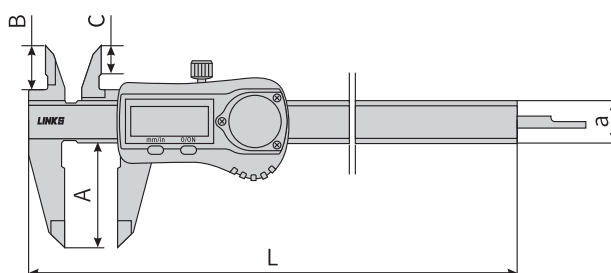
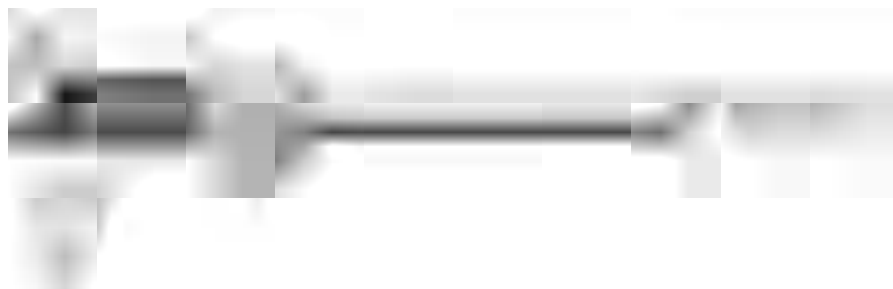

单位 (Unit) : mm

编号 Item No.	测量范围 Measuring Range	分辨力 Resolution	示值误差 Indication Error	L	A	B	C	a	质量 Weight(kg)	备注 Remarks
605E-01	0-150	0.01	±0.03	235	40	21	16.5	16	0.213	金属壳 II 型
605E-02	0-200	0.01	±0.03	285	50	24	19.5	16	0.213	金属壳 II 型
605E-03	0-300	0.01	±0.04	390	60	26	21.5	16	0.319	金属壳 II 型

订货说明：按产品对应的编号订货。

Order Description: order according to the number of products.



深度游标卡尺 606

Depth Vernier Gauges 606

- 采用优质碳素工具钢制造
- 尺身尾部带限位螺钉，使用中主尺不会脱出
- 用于测量深度，台阶等
- 符合 GB 标准
- Made of carbon steel.
- With limit screw to prevent the slider from pulling out.
- The depth vernier gauges can be used to measure depth and step.
- It conforms to GB standard.

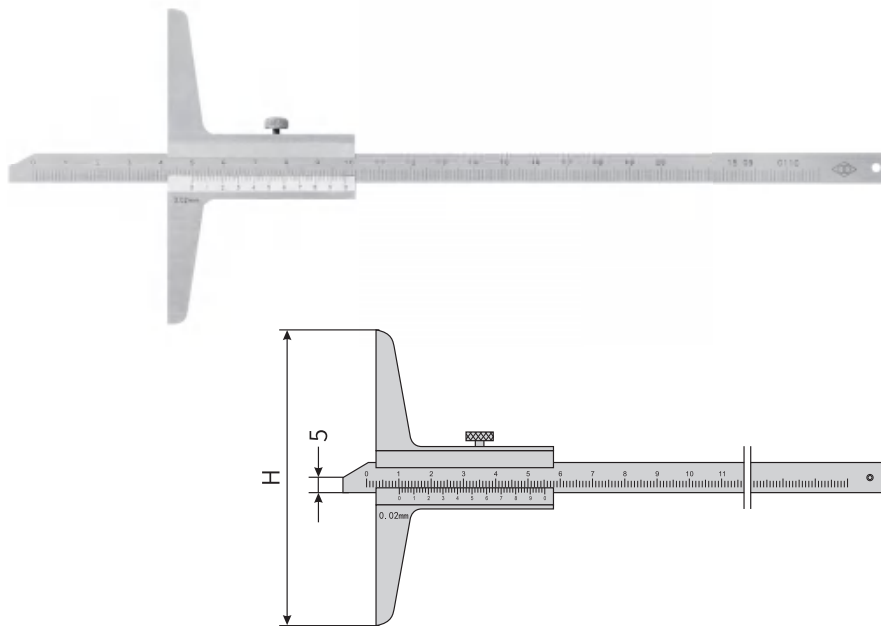

单位 (Unit) : mm

编号 Item No.	测量范围 Measuring Range	分度值 Graduation Value	示值误差 Indication Error	H	a	质量 Weight(kg)	备注 Remarks
606-01	0-200	0.02	±0.03	100	10	0.220	
606-03	0-300	0.02	±0.04	100	10	0.255	
606-05	0-500	0.02	±0.05	100	10	0.323	
606-07	0-1000	0.02	±0.07	100	10	0.498	
606-09	0-1500	0.02	±0.11	300	28	3.200	★ ▲

注： ★ 为特殊订货 ▲ 为企业标准。

Note: ★ For a special order ▲ For enterprise standards .



带表深度卡尺 616

Dial Depth Gauges 616

- 采用优质碳素工具钢制造
- 用于测量盲孔或凹槽深度及台阶高度
- 主尺、尺框刻线面无光镀铬
- 读数直观
- 符合 GB 标准
- Made of carbon steel.
- Used for measuring blind hole or groove depth and bench height.
- The main scale and the vernier are satin chromed.
- Easy to read.
- It conforms to GB standard.

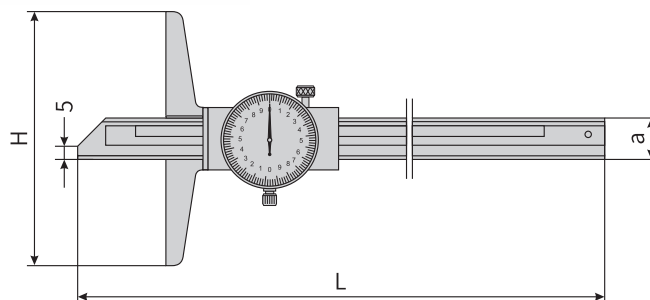

单位 (Unit) : mm

编号 Item No.	测量范围 Measuring Range	分度值 Graduation Value	示值误差 Indication Error	L	H	a	质量 Weight(kg)
616-01	0-200	0.02	±0.03	285	100	16	0.272
616-02	0-300	0.02	±0.04	385	100	16	0.308

订货说明：按产品对应的编号订货。

Order Description: order according to the number of products.



电子数显深度卡尺 615

Electronic Digital Depth Gauges 615

- 采用优质不锈钢制造
- 读数直观、清晰方便
- 具有公英制快速转换、任意位置置零等功能
- 用于精确测量孔深和台阶高度
- 带数据输出
- 符合 GB 标准
- Made of stainless steel.
- Big LCD display, easy to read.
- Fast switch-inch switch, zero setting at any position.
- Easy use for depth and step measurements.
- Data output.
- It conforms to GB standard.



615-01 615-02

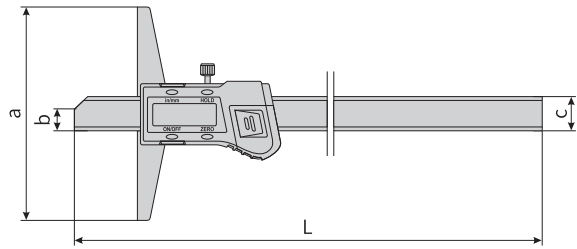

615-03 615-04

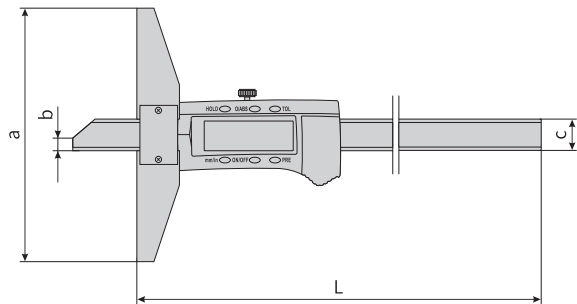

单位 (Unit) : mm

编号 Item No.	测量范围 Measuring Range	分辨力 Resolution	示值误差 Indication Error	L	a	b	c	质量 Weight(kg)	备注 Remarks
615-01	0-200	0.01	±0.03	280	100	6	14.5	0.228	金属壳
615-02	0-300	0.01	±0.04	380	100	6	14.5	0.270	金属壳
615-03	0-500	0.01	±0.05	585	120	7	15	0.354	金属壳
615-04	0-1000	0.01	±0.07	1188	150	7	18	1.670	金属壳 ★

注：★ 为特殊订货。

Note: ★ For a special order .



高度游标卡尺 609

Height Vernier Gauges 609

- 采用碳钢制造
- 硬质合金划线爪
- 带微动装置
- 流线型底座设计符合人机工程学，测量方便，握感舒适
- 符合 GB 标准
- Made of carbon steel.
- Carbide tipped scriber.
- With fine adjustment.
- New design base for easy holding.
- It conforms to GB standard.

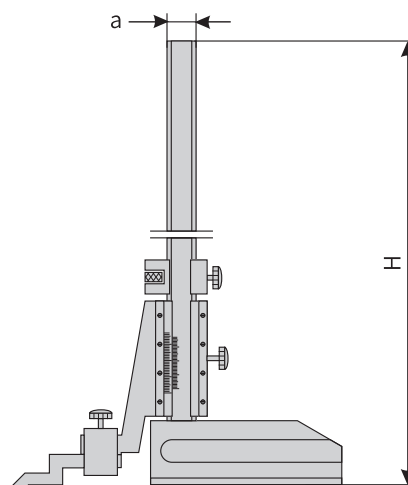

单位 (Unit) : mm

编号 Item No.	测量范围 Measuring Range	分度值 Graduation Value	示值误差 Indication Error	H	a	质量 Weight(kg)
609-01	0-200	0.02	±0.03	330	17	1.8
609-05	0-300	0.02	±0.04	430	17	2.1
609-09	0-500	0.02	±0.05	686	23	4.0
609-13	0-1000	0.02	±0.07	1195	35	8.3

订货说明：按产品对应的编号订货。

Order Description: order according to the number of products.



带表高度卡尺 617

Dial Height Gauges 617

- 尺身采用优质碳素工具钢制造
 - 采用齿条、齿轮传动原理
 - 带微动装置
 - 用于高度测量及划线
 - 符合 GB 标准
- Made of carbon steel.
 - The gauges are a kind of measuring tool of converting relative motion of the gauge body.
 - With fine adjustment.
 - They are used for measuring height and scribing.
 - It conforms to GB standard.

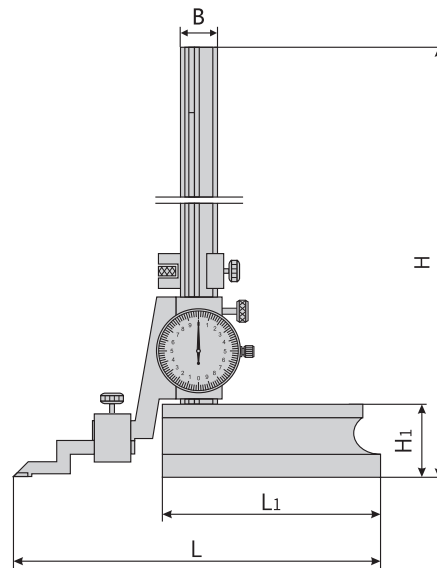

单位 (Unit) : mm

编号 Item No.	测量范围 Measuring Range	分度值 Graduation Value	示值误差 Indication Error	L	L ₁	H	H ₁	B	质量 Weight(kg)
617-02	0-300	0.02	±0.04	206	116	455	37	21	2.05

订货说明：按产品对应的编号订货。

Order Description: order according to the number of products.



电子数显高度卡尺 611

Electronic Digital Height Gauges 611

- 用于高度测量和划线
 - 带电源开关
 - 任意位置清零，便于相对测量与绝对测量转换
 - 任意位置公制与英制转换
 - 带数据保持功能
 - 带预置功能
 - 带公差带设置功能
 - 带有微调装置
 - 划线爪镶硬质合金
 - 符合 GB 标准
- Easy use of height measurements and scribing.
 - Power on/off.
 - Zero-setting at any position , convenient for relative and absolute measure conversion.
 - mm/inch conversion at any position.
 - Date hold.
 - Preset any reading at any position.
 - Tolerances setting.
 - With fine adjustment carriage.
 - Carbide-tipped scriber facilitates fine scribing on work pieces.
 - It conforms to GB standard.

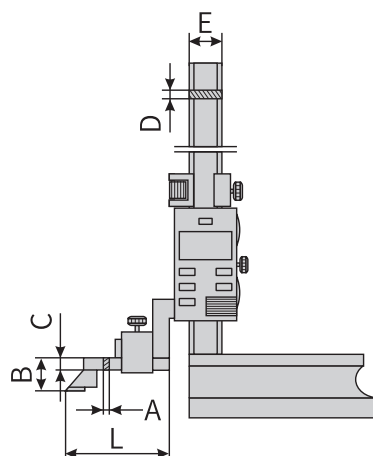

单位 (Unit) : mm

编号 Item No.	测量范围 Measuring Range	分辨力 Resolution	示值误差 Indication Error	L	A	B	C	D	E	质量 Weight(kg)	备注 Remarks
611-01	0-200	0.01	±0.03	76	6	25	8	6	23	2.0	金属壳
611-02	0-300	0.01	±0.04	76	6	25	8	6	23	2.2	金属壳
611-03	0-500	0.01	±0.05	105	10	25	10	10.5	31	5.0	金属壳
611-04	0-1000	0.01	±0.07	110	10	39	15	16	50	8.205	金属壳
611-05	0-1500	0.01	±0.10	110	10	39	15	16	50	17.97	金属壳
611-06	0-2000	0.01	±0.14	110	10	39	15	16	50	20.5	金属壳



万能角度尺 613

Universal Bevel Protractors 613

- 采用优质碳素工具钢制造
- 专用于角度的精确测量
- 整体热处理，测量面淬硬
- 符合 GB 标准
- Made of carbon steel.
- Used for angle measurements.
- The beam and the slider are entirely heat-treated, and all the measuring faces are hardened.
- It conforms to GB standard.

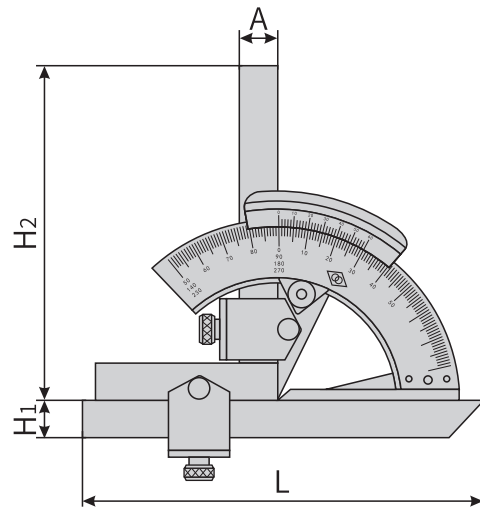
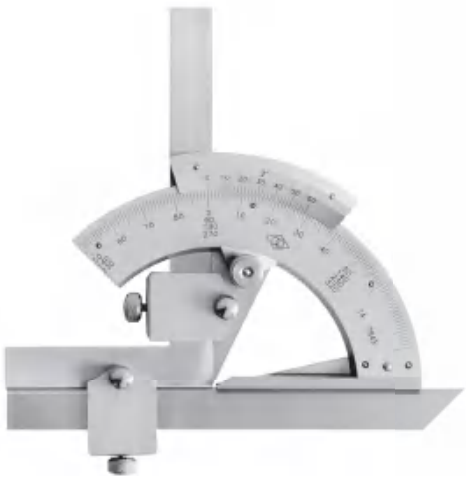

单位 (Unit) : mm

编号 Item No.	测量范围 Measuring Range	分度值 Graduation Value	示值误差 Indication Error	L	H ₁	H ₂	A	质量 Weight(kg)
613-01	0-320°	2'	±2'	150	14	125	14	0.367
613-02	0-320°	5'	±5'	150	14	125	14	0.367

订货说明：按产品对应的编号订货。

Order Description: order according to the number of products.



外径千分尺 701

Outside Micrometer 701

- 外尺寸精密测量
- 硬质合金测量面
- 棘轮测力
- 符合 GB 标准
- External dimension precision measurement.
- Cemented carbide surface.
- Ratchet force.
- It conforms to GB standard.

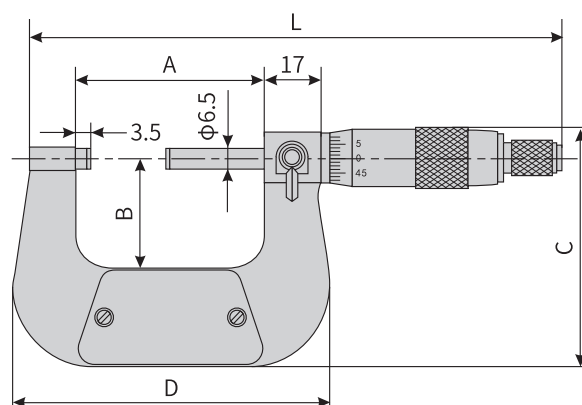

单位 (Unit) : mm

编号 Item No.	测量范围 Measuring Range	分度值 Graduation Value	示值误差 Indication Error	L	A	B	C	D	质量 Weight(kg)
701-01	0-25	0.01	0.004	129	32	24	54	62	0.208
701-02	25-50	0.01	0.004	161	57.3	32	71	97	0.332
701-03	50-75	0.01	0.005	186	82.3	44.5	85.5	128	0.407
701-04	75-100	0.01	0.005	211	107	57	104	155	0.522
701-05	100-125	0.01	0.006	236	132.3	70	119	194	0.620
701-06	125-150	0.01	0.006	261	157.3	82	136	227	0.811

订货说明：按产品对应的编号订货。

Order Description: order according to the number of products.



外径千分尺 702

Outside Micrometer 702

- 外尺寸精密测量
 - 硬质合金测量面
 - 棘轮测力
 - 分度值 0.001mm
 - 符合 GB 标准
- External dimension precision measurement.
 - Cemented carbide surface.
 - Ratchet force.
 - Graduation value 0.001mm.
 - It conforms to GB standard.

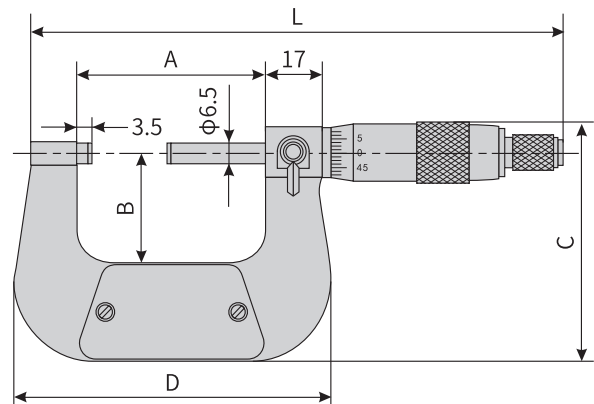

单位 (Unit) : mm

编号 Item No.	测量范围 Measuring Range	分度值 Graduation Value	示值误差 Indication Error	L	A	B	C	D	质量 Weight(kg)
702-01	0-25	0.001	0.002	129	32	24	54	62	0.208
702-02	25-50	0.001	0.002	161	57.3	32	71	97	0.332
702-03	50-75	0.001	0.003	186	82.3	44.5	85.5	128	0.407
702-04	75-100	0.001	0.003	211	107	57	104	155	0.522
702-05	100-125	0.001	0.004	236	132	70	119	194	0.621
702-06	125-150	0.001	0.004	261	157	82	136	227	0.809

订货说明：按产品对应的编号订货。

Order Description: order according to the number of products.



外径千分尺 703B

Outside Micrometer 703B

- 外尺寸精密测量
- 硬质合金测量面
- 棘轮测力
- 符合 GB 标准
- External dimension precision measurement.
- Cemented carbide surface.
- Ratchet force.
- It conforms to GB standard.

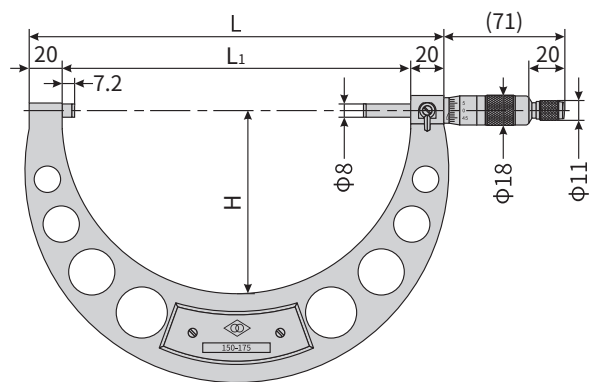

单位 (Unit) : mm

编号 Item No.	测量范围 Measuring Range	分度值 Graduation Value	示值误差 Indication Error	H	L ₁	L	质量 Weight(kg)
703B-01	150-175	0.01	0.007	226	186	98.1	0.803
703B-02	175-200	0.01	0.007	251	211	110.7	0.982
703B-03	200-225	0.01	0.008	276	236	123.2	1.073
703B-04	225-250	0.01	0.008	301	261	135.6	1.180
703B-05	250-275	0.01	0.009	326	286	148.1	1.330
703B-06	275-300	0.01	0.009	351	311	160.6	1.480

订货说明: 按产品对应的编号订货。

Order Description: order according to the number of products.



外径千分尺（管结构）704 705

Outside Micrometers (Tube Structure) 704 705

- 可调范围大，精度高
- 硬质合金测量面
- 重量轻，刚性好
- 棘轮测力
- 符合 GB 标准

- Adjustable range, high precision.
- Cemented carbide measuring surface.
- Light weight, good rigidity.
- Ratchet force.
- It conforms to GB standard.



704

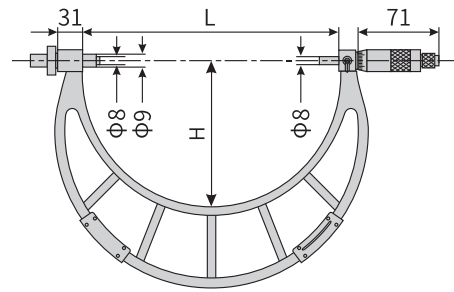

705

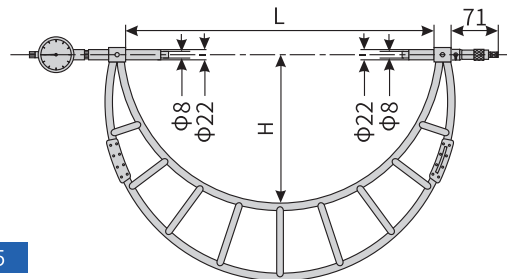

单位 (Unit) : mm

编号 Item No.	测量范围 Measuring Range	分度值 Graduation Value	示值误差 Indication Error	L	H	质量 Weight(kg)	备注 Remarks
704-01	300-400	0.01	0.011	407	217	1.9	
704-02	400-500	0.01	0.013	507	267	2.2	
704-03	500-600	0.01	0.015	607	317	2.9	
704-04	600-700	0.01	0.016	707	367	3.6	
704-05	700-800	0.01	0.018	807	417	4.0	
704-06	800-900	0.01	0.020	907	467	4.7	
704-07	900-1000	0.01	0.022	1007	517	4.9	
705-01	1000-1500	0.01	0.029	1530	768	13.5	▲
705-02	1500-2000	0.01	0.037	2030	1017	17.5	▲
705-03	2000-2500	0.01	0.044	2530	1267	21.5	▲
705-04	2500-3000	0.01	0.052	3030	1516	25.5	▲

注： ▲ 为 JB/T 标准。 Note: ▲ For JB/T standards.



数显外径千分尺 704A

Digital Display Outside Micrometer 704A

- 通电后液晶显示值即为绝对测量的初始值
- 硬质合金测量面，喷漆尺架
- 一粒 SR44 电池，功耗 <35 μ A，自动断电
- 电源开关，初绝值设置
- 公、英制转换
- 绝对和相对测量转换
- 数据输出接口
- 电池电压低压报警
- Display the original data of the absolute measurement after switch on.
- Hard metal measuring surfaces, painted frame.
- One SR44 battery, power consumption <35 μ A, auto power off.
- Power switch, Original data set.
- mm/inch conversion.
- Absolute and relative measurement conversion.
- Output interface.
- Low battery alarm.

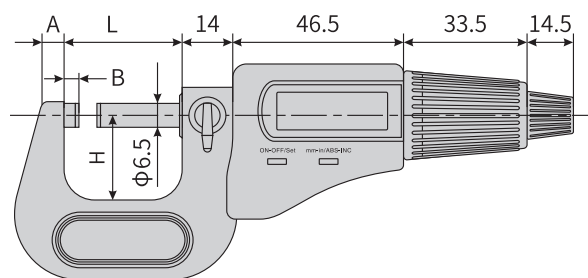

单位 (Unit) : mm

编号 Item No.	测量范围 Measuring Range	分辨力 Resolution	示值误差 Indication Error	A	B	H	L	质量 Weight(kg)
704A-01	0-25	0.001	0.002	6	3	24	32	0.4
704A-02	25-50	0.001	0.002	8	3	32	57	0.5
704A-03	50-75	0.001	0.003	8	3	45	82	0.7
704A-04	75-100	0.001	0.003	8	3	57	107	0.9
704A-05	100-125	0.001	0.003	8	3	70	133	1.0
704A-06	125-150	0.001	0.003	8	3	82	158	1.1
704A-07	150-175	0.001	0.004	8	5.5	95	183	1.2
704A-08	175-200	0.001	0.004	8	5.5	107	209	1.3

订货说明：按产品对应的编号订货。

Order Description: order according to the number of products.



数显外径千分尺 704B

Digital Display Outside Micrometer 704B

- 通电后液晶显示值即为绝对测量的初始值
 - 硬质合金测量面，喷漆尺架
 - 电源开关，初始值设置
 - 公、英制转换
 - 数据保持
 - 绝对和相对测量转换
 - 3V 锂电池供电，自动断电
 - 电池电压低压报警
 - 符合 GB 标准
- Display the original data of the absolute measurement after switch on.
 - Hard metal measuring surfaces, spray frame.
 - Power switch, Original data set.
 - mm/inch conversion.
 - Data retention.
 - Absolute and relative measurement conversion.
 - 3V lithium battery power supply, automatic power off.
 - Low battery alarm.
 - It conforms to GB standard.

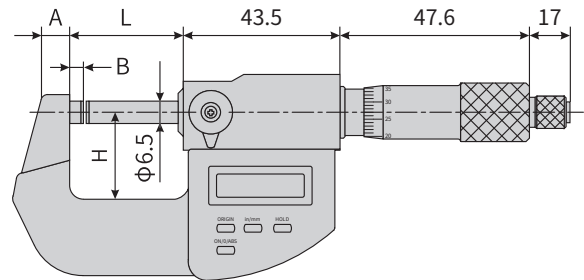

单位 (Unit) : mm

编号 Item No.	测量范围 Measuring Range	分辨力 Resolution	示值误差 Indication Error	A	B	H	L	质量 Weight(kg)
704B-01	0-25	0.001	0.002	7	3	24.5	33.5	0.4

订货说明：按产品对应的编号订货。

Order Description: order according to the number of products.



测微头 706

Micrometer Heads 706

- 测微头螺距 0.5mm
 - 测量面直径为 $\phi 6.5\text{mm}$ 和 $\phi 8\text{mm}$
 - 夹持径 $\phi 12\text{mm}$ 和 $\phi 13\text{mm}$
 - 棘轮测力
 - 符合 GB 标准
- The thread pitch is 0.5mm.
 - The diameter of the measuring face is $\phi 6.5\text{mm}$ and $\phi 8\text{mm}$.
 - The holding diameter is $\phi 12\text{mm}$ and $\phi 13\text{mm}$
 - Ratchet force.
 - It conforms to GB standard.

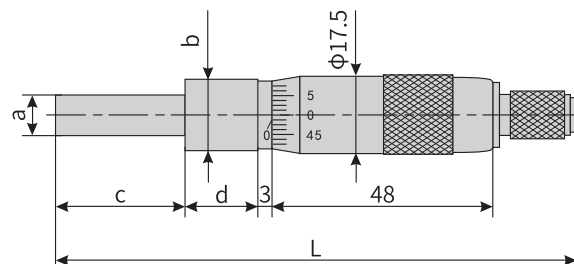

单位 (Unit) : mm

编号 Item No.	测量范围 Measuring Range	分度值 Graduation Value	L	a	b	c	d	质量 Weight(kg)
706-01	0-25	0.01	118	$\phi 6.5$	$\phi 12$	28.5	17.5	0.110
706-02	0-25	0.001	120.5	$\phi 8$	$\phi 13$	28.5	20	0.119

订货说明：按产品对应的编号订货。

Order Description: order according to the number of products.



内径千分尺 707 708 709

Inside Micrometers 707 708 709

- 用于内尺寸精密测量
- 组合接杆，测量范围大
- 符合 GB 标准

- For internal size precision measurement.
- The combined connecting rod, the measuring range is big.
- It conforms to GB standard.

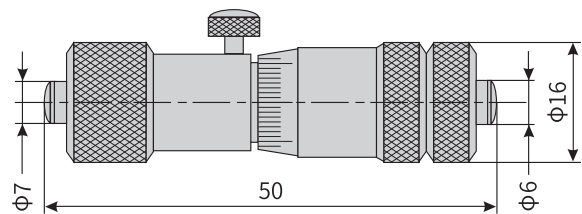

707

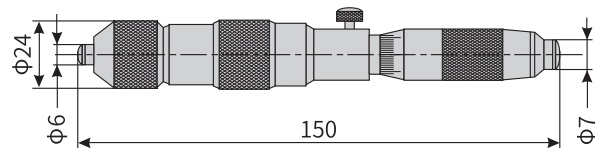

708

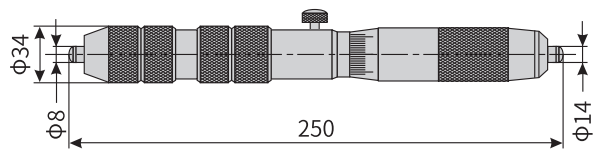

709

单位 (Unit) : mm

编号 Item No.	测量范围 Measuring Range	分度值 Graduation Value	示值误差 Indication Error	质量 Weight(kg)	备注 Remarks
707-01	50-250	0.01	0.008	0.266	接杆: 13/25/50/100
707-02	50-600	0.01	0.016	0.626	接杆: 13/25/50/100/200
708-01	150-1500	0.01	0.027	4.8	
708-02	150-2000	0.01	0.032	5.6	
708-03	150-3000	0.01	0.05	8.2	
709-01	250-4000	0.01	0.06	7.0	
709-02	250-5000	0.01	0.072	9.6	
709-03	250-6000	0.01	0.09	19.0	



螺纹千分尺 711

Thread Micrometer 711

- 用于测量螺纹中径
 - 具有 60° 锥型和 V 型测头
 - 测头真空炉淬火、高精度磨削
 - 符合 GB 标准
- Used to measure the diameter of the thread.
 - With 60° cone type and V type measuring head.
 - Probe with vacuum furnace hardening, high precision grinding.
 - It conforms to GB standard.

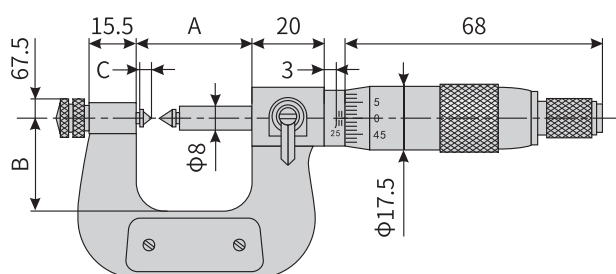

单位 (Unit) : mm

编号 Item No.	测量范围 Measuring Range	分度值 Graduation Value	示值误差 Indication Error	A	B	C	质量 Weight(kg)
711-01	0-25	0.01	0.004	37.5	25	3	0.289
711-02	25-50	0.01	0.004	62.5	35	3.12	0.377
711-03	50-75	0.01	0.005	87.5	47.5	3.35	0.486
711-04	75-100	0.01	0.005	112.5	60	3.71	0.644
711-05	100-125	0.01	0.006	137.5	72.5	4.33	0.824
711-06	125-150	0.01	0.006	162.5	85	5.31	1.022

订货说明：按产品对应的编号订货。

Order Description: order according to the number of products.



数显螺纹千分尺 711A

Digital Display Thread Micrometer 711A

- 用于测量螺纹中径
 - 具有 60° 锥型和 V 型测头
 - 带数据输出
 - 符合 GB 标准
- Used to measure the diameter of the thread.
 - With 60° cone type and V type measuring head.
 - Data output.
 - It conforms to GB standard.

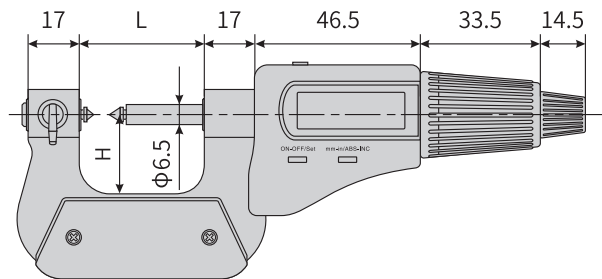

单位 (Unit) : mm

编号 Item No.	测量范围 Measuring Range	分辨力 Resolution	示值误差 Indication Error	L	H	质量 Weight(kg)
711A-01	0-25	0.001	0.004	42	26	0.7
711A-02	25-50	0.001	0.004	67	38	0.8
711A-03	50-75	0.001	0.005	92	50	1.1
711A-04	75-100	0.001	0.005	118	62	1.2
711A-05	100-125	0.001	0.006	143	70	1.4
711A-06	125-150	0.001	0.006	168	82	1.8

订货说明：按产品对应的编号订货。

Order Description: order according to the number of products.



公法线千分尺 712

Gear Tooth Micrometer 712

- 用于测量齿轮公法线长度
- 测砧真空炉淬火、量面经过精密研磨
- 符合 GB 标准
- Used to measure the gear base tangent length.
- Anvil with vacuum furnace hardening, measuring face with high precision grinding.
- It conforms to GB standard.

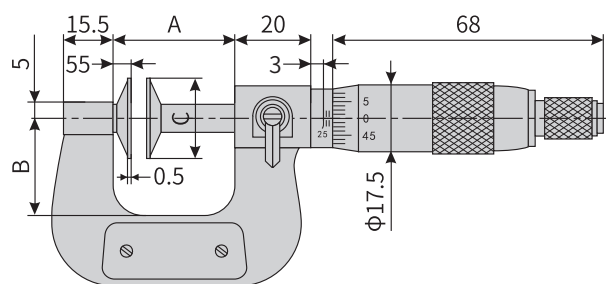

单位 (Unit) : mm

编号 Item No.	测量范围 Measuring Range	分度值 Graduation Value	示值误差 Indication Error	A	B	C	质量 Weight(kg)
712-01	0-25	0.01	0.004	37.5	25	φ20	0.274
712-02	25-50	0.01	0.004	62.5	35	φ25	0.356
712-03	50-75	0.01	0.005	87.5	47.5	φ25	0.454
712-04	75-100	0.01	0.005	112.5	60	φ25	0.600
712-05	100-125	0.01	0.006	137.5	72.5	φ25/φ30	0.772
712-06	125-150	0.01	0.006	162.5	85	φ25/φ30	0.961
712-07	150-175	0.01	0.007	196	107	φ30	1.350
712-08	175-200	0.01	0.007	221	119	φ30	1.620
712-09	200-225	0.01	0.008	246	132	φ30	1.840
712-10	225-250	0.01	0.008	271	144	φ30	2.030
712-11	250-275	0.01	0.010	296	157	φ30	2.300
712-12	275-300	0.01	0.010	321	169	φ30	2.680
712-13	300-325	0.01	0.012	346	180.4	φ32	3.100
712-14	325-350	0.01	0.013	371	192.9	φ32	3.120



深度千分尺 713

Depth Micrometers 713

- 用于深度、台阶的测量
- 两种测头可供选择
- 棘轮测力
- 符合 GB 标准

- Used in depth, the steps of measurement.
- Two kinds of measuring head to choose from.
- Ratchet wheel load.
- It conforms to GB standard.

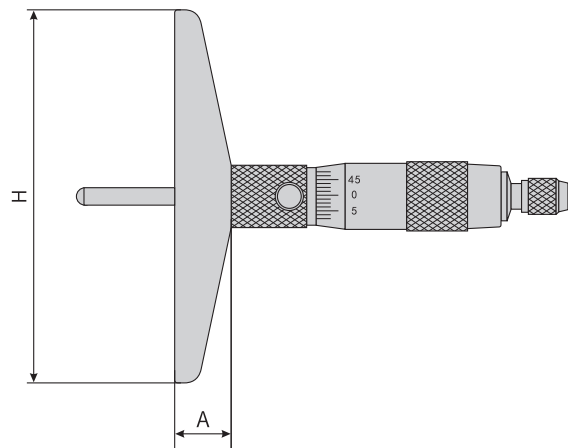

单位 (Unit) : mm

编号 Item No.	测量范围 Measuring Range	分度值 Graduation Value	示值误差 Indication Error	H	A	质量 Weight(kg)	备注 Remarks
713-01	0-25	0.01	0.004	100	15	0.45	平测头
713-02	0-50	0.01	0.005	100	15	0.50	平测头
713-03	0-100	0.01	0.006	100	15	0.55	平测头
713-04	0-150	0.01	0.007	100	15	0.60	平测头
713-05	0-200	0.01	0.008	100	15	0.60	平测头
713-06	0-300	0.01	0.010	100	15	0.90	平测头
713-01A	0-25	0.01	0.004	100	15	0.45	球测头
713-02A	0-50	0.01	0.005	100	15	0.50	球测头
713-03A	0-100	0.01	0.006	100	15	0.55	球测头
713-04A	0-150	0.01	0.007	100	15	0.60	球测头
713-05A	0-200	0.01	0.008	100	15	0.60	球测头
713-06A	0-300	0.01	0.010	100	15	0.90	球测头



数显深度千分尺 713A

Digital Display Depth Micrometer 713A

- 用于深度、台阶的测量
- 两种测头可供选择
- 带数据输出
- 符合 Q/HLR 企业标准
- Used in depth, the steps of measurement.
- Two kinds of measuring head to choose from.
- Data output.
- In accordance with Q/HLR enterprise standard.

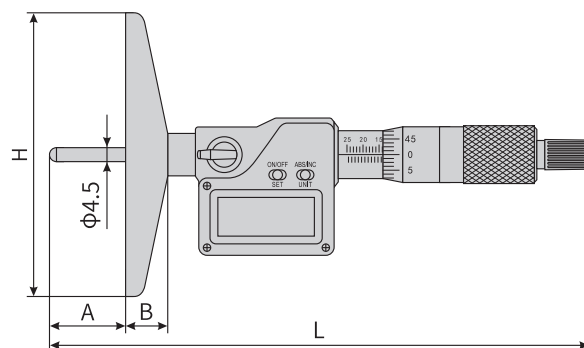

单位 (Unit) : mm

编号 Item No.	测量范围 Measuring Range	分辨力 Resolution	示值误差 Indication Error	A	B	L	H	质量 Weight(kg)
713A-01	0-25	0.001	0.004	25	15	131	100	0.6
713A-02	0-100	0.001	0.005	25	15	131	100	0.6
713A-06	0-300	0.001	0.007	25	15	131	100	0.7
713A-21	0-25	0.001	0.004	25	15	131	100	0.7
713A-22	0-100	0.001	0.005	25	15	131	100	1.0
713A-26	0-300	0.001	0.007	25	15	131	100	1.3

订货说明：按产品对应的编号订货。

Order Description: order according to the number of products.



壁厚千分尺 719

Wall Thickness Micrometer 719

- 适用于管子壁厚的测量
- 硬质合金测量面
- 棘轮测力
- 符合 GB 标准
- Measurement of wall thickness of pipe.
- Cemented carbide measuring surface.
- Ratchet force.
- It conforms to GB standard.

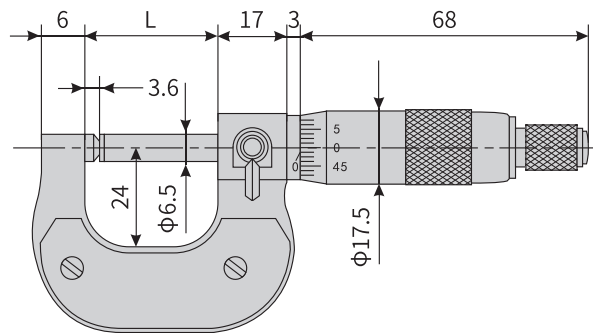

单位 (Unit) : mm

编号 Item No.	测量范围 Measuring Range	分度值 Graduation Value	示值误差 Indication Error	L	质量 Weight(kg)
719-01	0-25	0.01	0.004	32	0.208
719-02	25-50	0.01	0.004	57	0.400

订货说明：按产品对应的编号订货。

Order Description: order according to the number of products.



板厚千分尺 724

Plate Micrometer 724

- 适用钢板等板材的测量
 - 硬质合金测量面
 - 棘轮测力
 - 符合 Q/HLR 企业标准
- Measurement of steel plate and other plates.
 - Cemented carbide measuring surface.
 - Ratchet force.
 - In accordance with Q/HLR enterprise standard.

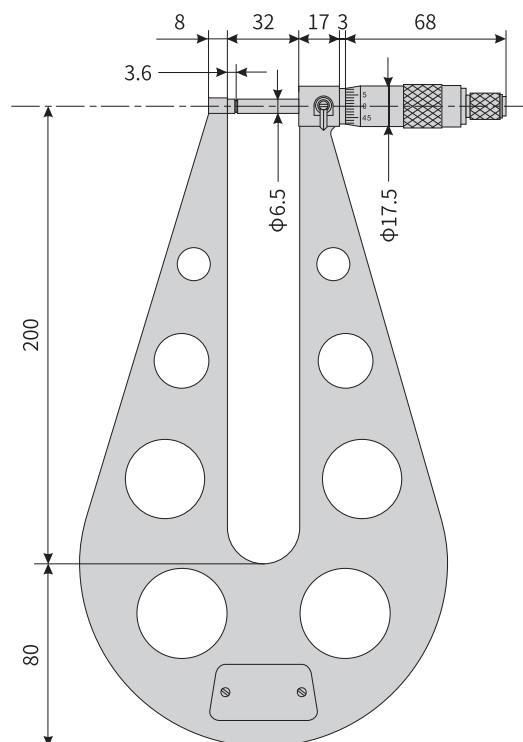

单位 (Unit) : mm

编号 Item No.	测量范围 Measuring Range	分度值 Graduation Value	示值误差 Indication Error	质量 Weight(kg)
724-01	0-10	0.01	0.005	0.266
724-02	0-25	0.01	0.005	1.300

订货说明：按产品对应的编号订货。

Order Description: order according to the number of products.



杠杆千分尺 725

Indicating Micrometer 725

- 适用于批量零件的精密测量
- 硬质合金测量面
- 符合 GB 标准
- Precision measurement is suitable for the batch parts.
- Carbide surface measurement.
- It conforms to GB standard.

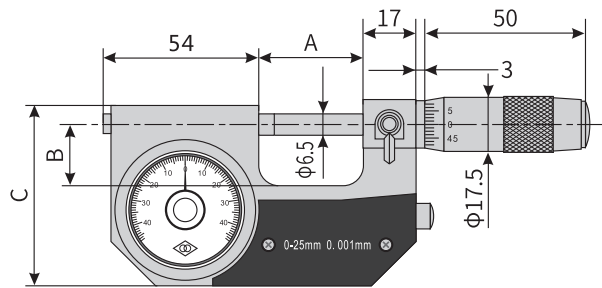

单位 (Unit) : mm

编号 Item No.	测量范围 Measuring Range	分度值 Graduation Value	示值误差 Indication Error	A	B	C	质量 Weight(kg)
725-01	0-25	0.001	0.003	32	20	58.5	0.485
725-02	25-50	0.001	0.003	57	26.5	63.5	0.551

订货说明：按产品对应的编号订货。

Order Description: order according to the number of products.



尖头千分尺 728 728B

Point Micrometer 728 728B

- 适用于钻头沟槽的测量
- 普通测量头和硬质合金测量头供选择
- 棘轮测力
- 符合 Q/HLR 企业标准
- Suitable for measuring the groove of drill bit.
- Cemented carbide measuring surface.
- Ratchet force.
- In accordance with Q/HLR enterprise standard.

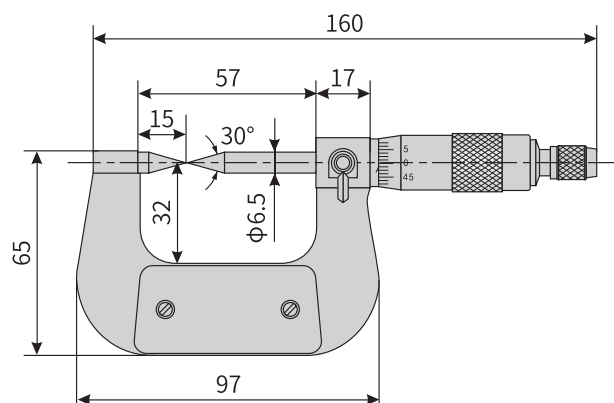

单位 (Unit) : mm

编号 Item No.	测量范围 Measuring Range	分度值 Graduation Value	示值误差 Indication Error	质量 Weight(kg)	备注 Remarks
728-01	0-25	0.01	0.004	0.32	普通测量头
728B-01	0-25	0.01	0.004	0.32	硬质合金测量头

订货说明：按产品对应的编号订货。

Order Description: order according to the number of products.



数显尖头千分尺 728A

Digital Display Pointed Micrometer 728A

- 适用于钻头等沟槽的测量
- 硬质合金测量面
- 棘轮测力
- 符合 GB 标准
- Suitable for measuring the groove of drill bit.
- Cemented carbide measuring surface.
- Ratchet force.
- It conforms to GB standard.

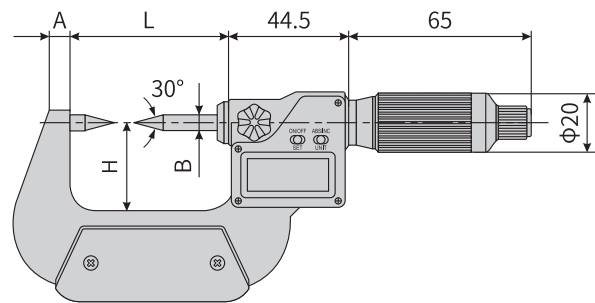

单位 (Unit) : mm

编号 Item No.	测量范围 Measuring Range	分辨力 Resolution	示值误差 Indication Error	L	H	A	B	质量 Weight(kg)
728A-01	0-25	0.001	0.004	34	25	6	φ6.5	0.6
728A-02	25-50	0.001	0.004	59.5	32	8	φ6.5	0.8
728A-03	50-75	0.001	0.005	84.5	44.5	8	φ6.5	1.1
728A-04	75-100	0.001	0.005	109.5	57	8	φ6.5	1.3

订货说明：按产品对应的编号订货。

Order Description: order according to the number of products.



小测头千分尺 729

Small Probe Micrometer 729

- 适用于花键、键槽等零件的测量
- 硬质合金测量面
- 棘轮测力
- 符合 GB 标准
- Suitable for measuring and other parts of the key way spline.
- Cemented carbide measuring surface.
- Ratchet force.
- It conforms to GB standard.

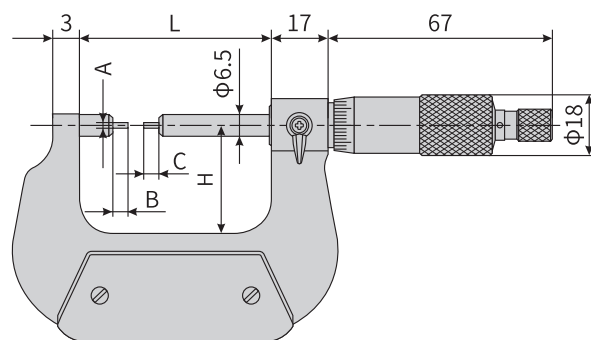

单位 (Unit) : mm

编号 Item No.	测量范围 Measuring Range	分度值 Graduation Value	示值误差 Indication Error	L	H	A	B	C	质量 Weight(kg)	备注 Remarks
729-01	0-25	0.01	0.004	32	24	φ2	5	5	0.5	A型测头
729-02	25-50	0.01	0.004	57	32	φ2	5	5	0.6	A型测头
729-03	50-75	0.01	0.005	82	45	φ2	5	5	0.8	A型测头
729-04	75-100	0.01	0.005	107	57	φ2	5	5	1.2	A型测头
729-05	100-125	0.01	0.006	133	70	φ2	5	5	1.4	A型测头
729-06	125-150	0.01	0.006	158	82	φ2	5	5	1.7	A型测头
729-07	150-175	0.01	0.007	183	95	φ2	5	5	1.9	A型测头
729-01B	0-25	0.01	0.004	32	24	φ3	10	10	0.5	B型测头
729-02B	25-50	0.01	0.004	57	32	φ3	10	10	0.6	B型测头
729-03B	50-75	0.01	0.005	82	45	φ3	10	10	0.8	B型测头
729-04B	75-100	0.01	0.005	107	57	φ3	10	10	1.2	B型测头
729-05B	100-125	0.01	0.006	133	70	φ3	10	10	1.4	B型测头
729-06B	125-150	0.01	0.006	158	82	φ3	10	10	1.7	B型测头
729-07B	150-175	0.01	0.007	183	95	φ3	10	10	1.9	B型测头



三爪内径千分尺 732

Internal Micrometers With Three-Point Contact 732

- 适用于孔的精密测量
 - 硬质合金测量面
 - 接长杆可测深孔尺寸
 - 棘轮测力
 - 符合 GB 标准
- Precision measurement for hole.
 - Cemented carbide measuring surface.
 - Length measurement of deep hole size.
 - Ratchet force.
 - It conforms to GB standard.

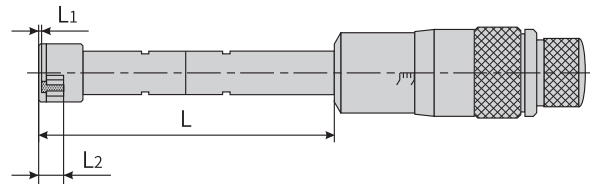

单位 (Unit) : mm

编号 Item No.	测量范围 Measuring Range	分度值 Graduation Value	示值误差 Indication Error	接长杆 After long pole	L	L1	L2	质量 Weight(kg)
732-01	6-8	0.001	0.004	100	54.5	1.5	2.5	1.0
732-02	8-10	0.001	0.004	100	54.5	1.5	2.5	1.0
732-03	10-12	0.001	0.004	100	54.5	1.5	2.5	1.0
732-04	12-16	0.005	0.004	150	80	0.5	6.0	1.2
732-05	16-20	0.005	0.004	150	80	0.5	6.0	1.4
732-06	20-25	0.005	0.004	150	90	0.5	8.0	1.6
732-07	25-30	0.005	0.004	150	90	0.5	8.0	1.6
732-08	30-40	0.005	0.004	150	97	0.5	13.5	3.1
732-09	40-50	0.005	0.005	150	97	0.5	13.5	3.1

订货说明：按产品对应的编号订货。

Order Description: order according to the number of products.



数显三爪内径千分尺 732A

Digital Display Internal Micrometers With Three-Point Contact 732A

- 适用于孔的精密测量
 - 硬质合金测量面
 - 接长杆可测深孔尺寸
 - 棘轮测力
 - 符合 GB 标准
- Precision measurement for hole.
 - Cemented carbide measuring surface.
 - Length measurement of deep hole size.
 - Ratchet force.
 - It conforms to GB standard.

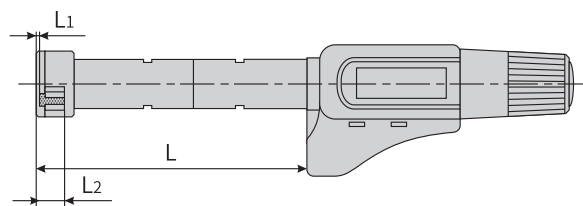

单位 (Unit) : mm

编号 Item No.	测量范围 Measuring Range	分辨力 Resolutio	示值误差 Indication Error	接长杆 After long pole	L	L1	L2	质量 Weight(kg)
732A-01	6-8	0.001	0.004	100	54.5	1.5	2.5	1.0
732A-02	8-10	0.001	0.004	100	54.5	1.5	2.5	1.0
732A-03	10-12	0.001	0.004	100	54.5	1.5	2.5	1.0
732A-04	12-16	0.001	0.004	150	80	0.5	6.0	1.2
732A-05	16-20	0.001	0.004	150	80	0.5	6.0	1.4
732A-06	20-25	0.001	0.004	150	90	0.5	8.0	1.6
732A-07	25-30	0.001	0.004	150	90	0.5	8.0	1.6
732A-08	30-40	0.001	0.004	150	97	0.5	13.5	3.1
732A-09	40-50	0.001	0.005	150	97	0.5	13.5	3.1

订货说明：按产品对应的编号订货。

Order Description: order according to the number of products.



内测千分尺 733

Inside Micrometer 733

- 适用于孔的精密测量
- 棘轮测力
- 符合 GB 标准
- Precision measurement for hole.
- Ratchet force.
- It conforms to GB standard.

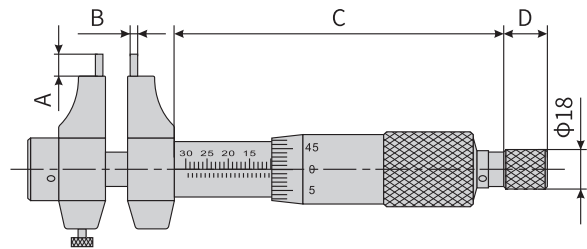

单位 (Unit) : mm

编号 Item No.	测量范围 Measuring Range	分度值 Graduation Value	示值误差 Indication Error	A	B	C	D	质量 Weight(kg)
733-01	5-30	0.01	0.005	5	φ2	26	17	0.3
733-02	25-50	0.01	0.006	5	φ2	38	17	0.4
733-03	50-75	0.01	0.007	5	φ2	50	17	0.4
733-04	75-100	0.01	0.008	5	φ2	62	17	0.4
733-05	100-125	0.01	0.009	5	φ2	70	17	0.5
733-06	125-150	0.01	0.009	5	φ2	82	17	0.5
733-07	150-175	0.01	0.010	5	φ2	95	17	0.7
733-08	175-200	0.01	0.010	5	φ2	107	17	0.7

订货说明：按产品对应的编号订货。

Order Description: order according to the number of products.



数显内测千分尺 733A

Digital Display Inside Micrometer 733A

- 适用于孔的精密测量
- 棘轮测力
- 符合 GB 标准
- Precision measurement for hole.
- Ratchet force.
- It conforms to GB standard.

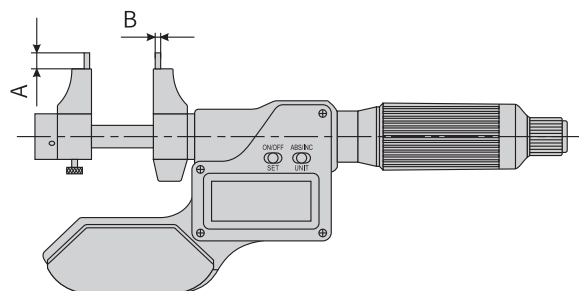

单位 (Unit) : mm

编号 Item No.	测量范围 Measuring Range	分辨力 Resolution	示值误差 Indication Error	A	B	质量 Weight(kg)
733A-01	5-30	0.001	0.005	5	φ2	0.5
733A-02	25-50	0.001	0.006	5	φ2	0.6
733A-03	50-75	0.001	0.007	5	φ2	0.6
733A-04	75-100	0.001	0.008	5	φ2	0.6
733A-05	100-125	0.001	0.009	5	φ2	0.6
733A-06	125-150	0.001	0.009	5	φ2	0.8
733A-07	150-175	0.001	0.010	5	φ2	0.9
733A-08	175-200	0.001	0.010	5	φ2	1.0

订货说明：按产品对应的编号订货。

Order Description: order according to the number of products.



叶片千分尺 734

Blade Micrometer 734

- 叶片式测量面
- 丝杆直进式
- 棘轮测力
- Vane measurement surface.
- Straight wire rod.
- Ratchet force.

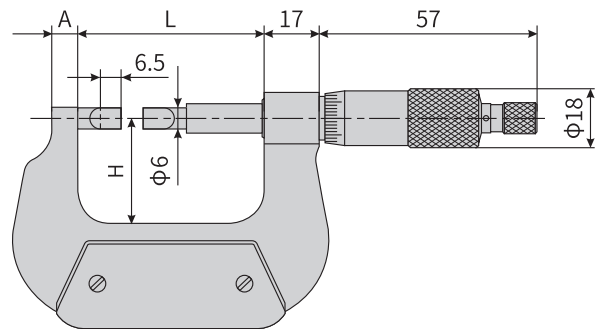

单位 (Unit) : mm

编号 Item No.	测量范围 Measuring Range	分度值 Graduation Value	示值误差 Indication Error	L	H	A	质量 Weight(kg)
734-01	0-25	0.01	0.004	42	26	6	0.5
734-02	25-50	0.01	0.004	67	38	8	0.6
734-03	50-75	0.01	0.005	92	50	8	0.8
734-04	75-100	0.01	0.005	118	62	8	1.1
734-05	100-125	0.01	0.006	143	70	8	1.4
734-06	125-150	0.01	0.006	168	82	8	1.7
734-07	150-175	0.01	0.007	192	95	8	1.9

订货说明：按产品对应的编号订货。

Order Description: order according to the number of products.



数显叶片千分尺 734A

Digital Blade Micrometer 734A

- 叶片式测量面
- 丝杆直进式
- 棘轮测力
- 带数据输出
- 符合 GB 标准
- Vane measurement surface.
- Straight wire rod.
- Ratchet force.
- Data output.
- It conforms to GB standard.

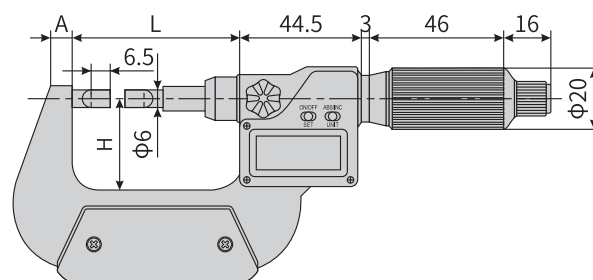

单位 (Unit) : mm

编号 Item No.	测量范围 Measuring Range	分辨力 Resolution	示值误差 Indication Error	L	H	A	质量 Weight(kg)
734A-01	0-25	0.001	0.002	34.5	25	6	0.6
734A-02	25-50	0.001	0.002	59.5	32	8	0.8
734A-03	50-75	0.001	0.003	84.5	44.5	8	1.0
734A-04	75-100	0.001	0.003	109.5	57	8	1.2
734A-05	100-125	0.001	0.003	135	70	10	1.4
734A-06	125-150	0.001	0.003	160.5	82	10	1.7
734A-07	150-175	0.001	0.004	186	94.5	12	2.0

订货说明：按产品对应的编号订货。

Order Description: order according to the number of products.



百分表 / 千分表 801 802 803

Dial Indicators 801 802 803

- 用于测量工件的几何形状误差及位置误差
- 结构简明，方便使用及保养，灵敏度高，精度稳定可靠
- 主要运动部件采用特殊耐磨不锈钢和高质量黄铜材料制成，具有良好耐磨及防锈性能
- 防震结构
- 宝石轴承
- 使用寿命长
- 刻度盘刻线清晰，方便读数
- Geometric error and position error of the workpiece.
- The dial indicators are simply assembled for easy usage and maintenance with high sensibility and stability.
- Main movement parts are made of special hard stainless steel and high quality brass, which has good rust-resistance performance.
- Earthquake proof structure.
- Jewel bearing.
- Long service life.
- Micro fine graduation for easy reading.



801 803

802

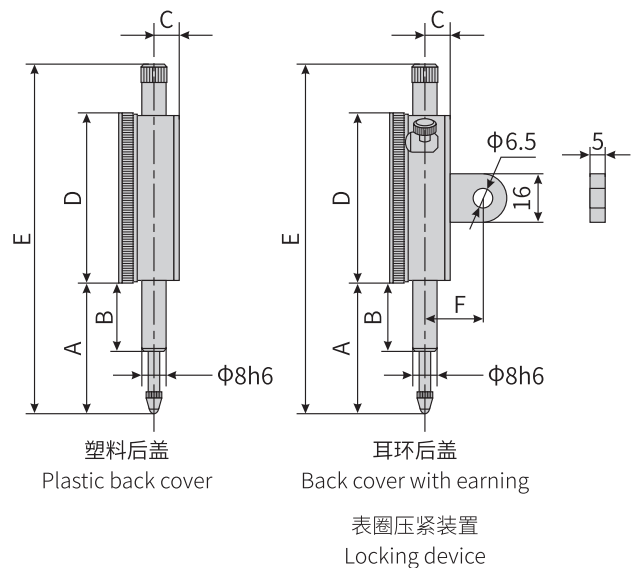

单位 (Unit) : mm

编号 Item No.	测量范围 Measuring Range	分度值 Graduation Value	示值误差 Indication Error	A	B	C	D	E	F	回程误差 Return error	质量 Weight(kg)
801-01A	0-5	0.01	±0.010	42.5	21.5	8.5	φ58.2	114.7	20	2 μm	0.211
801-02A	0-10	0.01	±0.014	42.5	21.5	8.5	φ58.2	114.7	20	2 μm	0.211
801-01	0-5	0.01	±0.016	42.5	21.5	8.5	φ58.2	114.7	20	3 μm	0.211
801-02	0-10	0.01	±0.020	42.5	21.5	8.5	φ58.2	114.7	20	3 μm	0.211
801-03	0-20	0.01	±0.025	52.5	21.5	8.5	φ58.2	124.7	20	--	0.217
801-04	0-30	0.01	±0.035	62.5	21.5	8.5	φ58.2	134.7	20	--	0.217
801-05	0-50	0.01	±0.040	91.8	31.5	10.0	φ76.4	176.5	--	--	0.109
802-01	0-3	0.01	±0.014	23.5	13.5	8.0	φ42.7	76.0	19	--	0.117
803-01A	0-1	0.001	±0.0025	38.5	21.5	8.5	φ58.2	108.7	20	1 μm	0.220
803-01	0-1	0.001	±0.005	38.5	21.5	8.5	φ58.2	108.7	20	2 μm	0.220

杠杆百分表 804/ 杠杆千分表 805

Dial Test Indicators 804 805

- 正反双向测量
- 测量杆可在 180°范围内转动测量
- 可配宝石测量头
- 体积小、精度高
- 符合 GB 标准
- Positive and negative measurement.
- 0-180° adjustable measuring head.
- Ruby ball head.
- Small side and high accuracy.
- It conforms to GB standard.

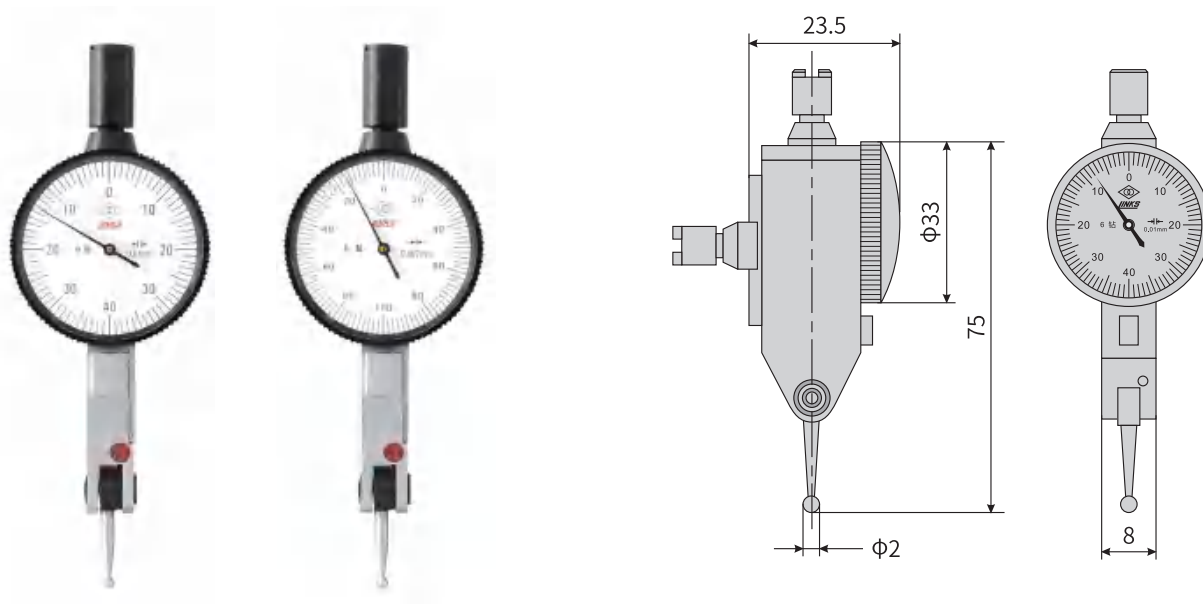

804-1 805-1

单位 (Unit) : mm

编号 Item No.	测量范围 Measuring Range	分度值 Graduation Value	示值误差 Indication Error Error(单向 / 双向)	质量 Weight(kg)	备注 Remarks
804-01	0-0.8	0.01	±0.010/±0.013	0.0062/0.0069	正反双向测量
805-01	0-0.2	0.002	±0.004/±0.006	0.06	正反双向测量

订货说明：按产品对应的编号订货。

Order Description: order according to the number of products.



数显指示表 806(IV型)

Electronic Digital Indicators Type 806(IV)

- 超大数字显示
- 绝对和相对测量
- 预置实际位置数值
- 可设置上下限公差值，自动判断偏差状态
- 任意位置公英制转换
- 标准数据输出口
- 高速自动寻找并保存最大值，最小值
- 跳动量检测
- 大容量 3V 锂电池
- 自动 / 手动关机
- 航空铝合金主体
- 玻璃容栅传感器
- 正负符号功能
- With large digital display.
- Relative and absolute measurement.
- Preplace real position value.
- Tolerance setting and OK or \pm NG discrimination.
- Metric/Inch system conversion at any position.
- With data output interface.
- Max/Min memory for reversal point search.
- Run-out detection.
- High capacity 3V Libattery.
- AUTO/MANUAL shutdown.
- The main body made by aerometal.
- Glass fixed fence sensor.
- Plus and minus sign function.

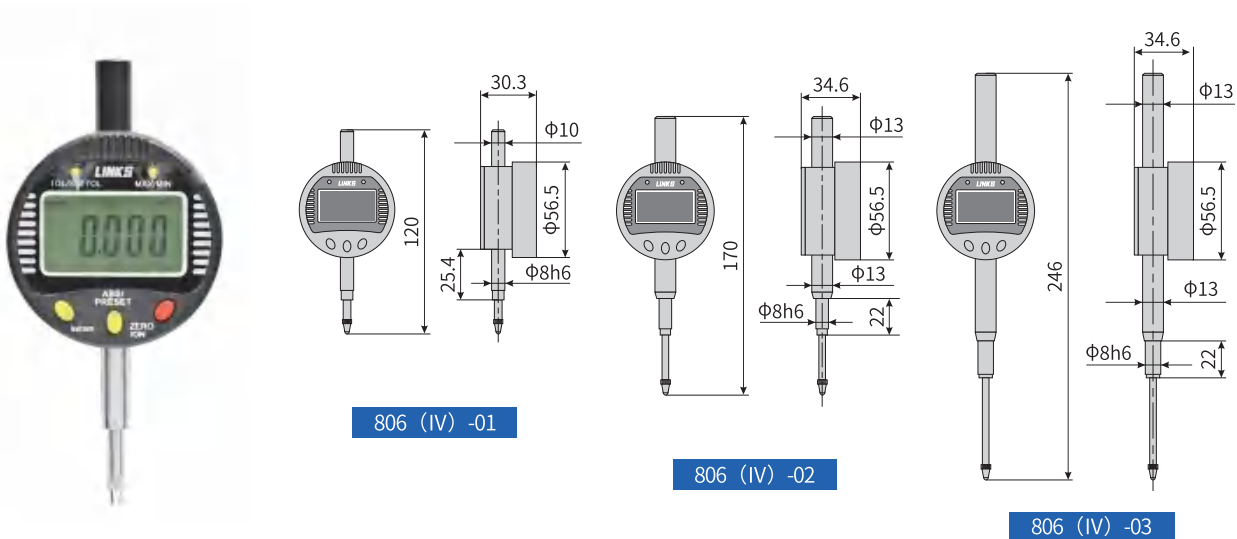

单位 (Unit) : mm

编号 Item No.	测量范围 Measuring Range	分辨力 Resolution (mm / ")	示值误差 Indication Error Error (单向 / 双向)	质量 Weight(kg)	备注 Remarks
806 (IV) -01	0-12.7	0.01/0.0005	0.02	0.097	五键
806 (IV) -02	0-25.4	0.01/0.0005	0.02	0.113	五键
806 (IV) -03	0-50	0.01/0.0005	0.02	0.123	五键
806 (IV) -04	0-12.7	0.001/0.00005	0.005	0.097	五键
806 (IV) -05	0-25.4	0.001/0.00005	0.005	0.113	五键
806 (IV) -06	0-50	0.001/0.00005	0.005	0.123	五键

数显指示表 806(V 型)

Electronic Digital Indicators Type 806(V)

- 数字和指针模拟显示
- 绝对和相对测量
- 预置实际位置数值
- 可设置上下限公差值，自动判断偏差状态
- 任意位置公英制转换
- 标准数据输出口
- 高速自动寻找并保存最大值，最小值
- 跳动量检测
- 大容量 3V 锂电池
- 自动 / 手动关机
- 航空铝合金主体
- 玻璃容栅传感器
- 正负符号功能
- Digital and pointer simulating display.
- Relative and absolute measurement.
- Preplace real position value.
- Tolerance setting and OK or \pm NG discrimination.
- Metric/Inch system conversion at any position.
- With data output interface.
- Max/Min memory for reversal point search.
- Run-out detection.
- High capacity 3V Libattery.
- AUTO/MANUAL shutdown.
- The main body made by aerometal.
- Glass fixed fence sensor.
- Plus and minus sign function.

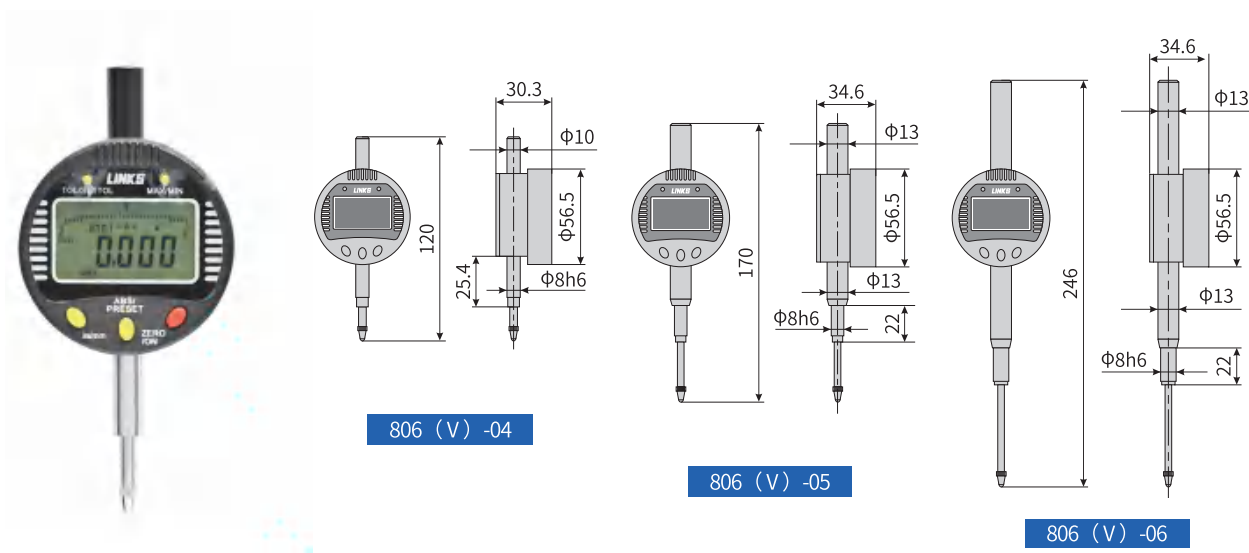

单位 (Unit) : mm

编号 Item No.	测量范围 Measuring Range	分辨力 Resolution (mm/ ")	示值误差 Indication Error Error(单向 / 双向)	质量 Weight(kg)	备注 Remarks
806 (V) -04	0-12.7	0.001/0.0005	0.005	0.097	五键 带模拟指针
806 (V) -05	0-25.4	0.001/0.0005	0.005	0.113	五键 带模拟指针
806 (V) -06	0-50	0.001/0.0005	0.005	0.123	五键 带模拟指针

订货说明：按产品对应的编号订货。

Order Description: order according to the number of products.

内径百分表 808 809

Bore Measuring Indicators 808 809

- 内径表是孔加工必备工具
- 适用于测量不同直径和不同深度的孔
- The bore measuring indicators is a necessary tool for hole machining.
- Suitable for measuring different diameters and different depth hole.

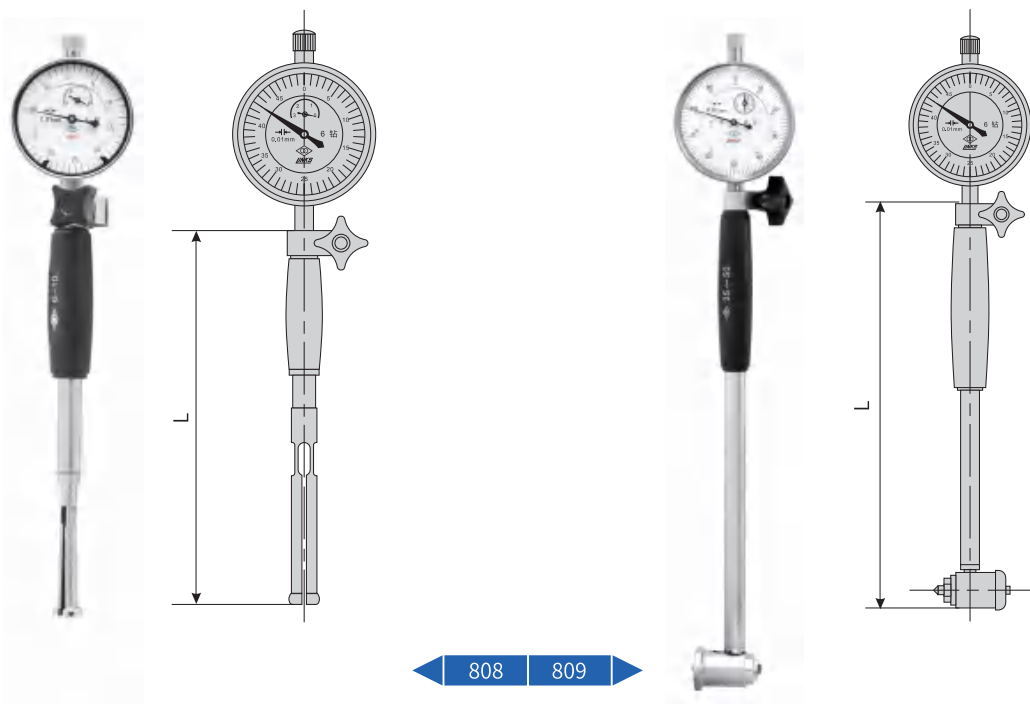

单位 (Unit) : mm

编号 Item No.	测量范围 Measuring Range	分度值 Graduation Value	示值误差 Indication Error	可测孔深 Measurable depth of holes	L	质量 Weight(kg)	备注 Remarks
808-01	3-4	0.01	±0.012	20	76	0.146	涨簧式
808-02	4-6	0.01	±0.012	30	96	0.158	Expanding head
808-03	6-10	0.01	±0.012	40	140	0.185	JB 标准
808-04	10-18	0.01	±0.012	130	200	0.405	JB standard
809-01	18-35	0.01	±0.012	135	224	0.320	护桥式 Lockating bridge GB 标准 GB standard
809-02	35-50	0.01	±0.015	150	251	0.420	
809-03	50-100	0.01	±0.015	200	316	0.595	
809-04	50-160	0.01	±0.018	200	316	0.625	
809-05	100-160	0.01	±0.018	300	410	1.120	
809-06	160-250	0.01	±0.018	400	510	1.345	
809-07	250-450	0.01	±0.018	500	610	1.955	



内径千分表 810 811

Bore Measuring Indicators 810 811

- 内径表是孔加工必备工具
- 适用于测量不同直径和不同深度的孔

- The bore measuring indicators is a necessary tool for hole machining.
- Suitable for measuring different diameters and different depth hole.

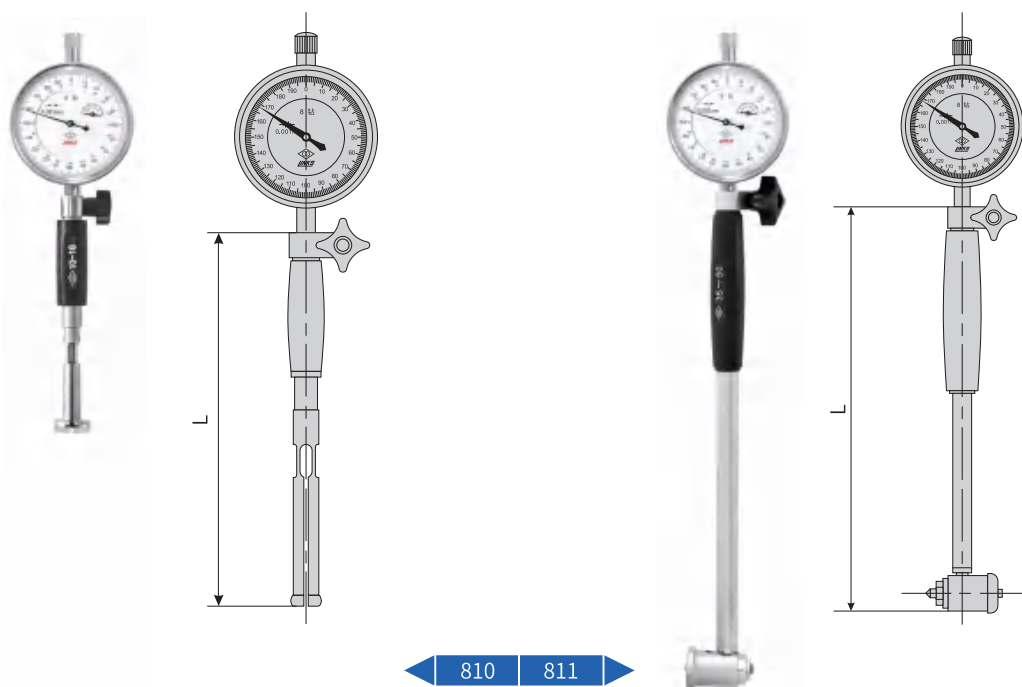

单位 (Unit) : mm

编号 Item No.	测量范围 Measuring Range	分度值 Graduation Value	示值误差 Indication Error	可测孔深 Measurable depth of holes	L	质量 Weight(kg)	备注 Remarks
810-01	3-4	0.001	±0.005	40	76	0.136	涨簧式
810-02	4-6	0.001	±0.006	40	96	0.137	Expanding head
810-03	6-10	0.001	±0.007	40	140	0.185	JB 标准
810-04	10-18	0.001	±0.007	40	200	0.405	JB standard
811-01	18-35	0.001	±0.006	135	224	0.320	护桥式 Lockating bridge GB 标准 GB standard
811-02	35-50	0.001	±0.006	150	251	0.420	
811-03	50-100	0.001	±0.007	200	316	0.595	
811-04	50-160	0.001	±0.007	200	316	0.625	
811-05	100-160	0.001	±0.007	300	410	1.120	
811-06	160-250	0.001	±0.007	400	510	1.345	
811-07	250-450	0.001	±0.007	500	610	1.955	



百分比较仪 / 千分比较仪 816

0.01mm Comparators And 0.001mm Comparators 816

- 用于测量工件尺寸及形位误差
 - 具有精度高的特点
 - 设有红、绿颜色表盘
 - 表盘颜色柔和、读数清晰、保护视力
 - 符合 Q/HLR 企业标准
- The 0.01mm and 0.001mm comparators are used for measuring dimension tolerance and shape and position tolerance of workpieces.
 - They have the feature of high accuracy.
 - The dials are in red or green.
 - The dials have effects such as soft colour, clear reading and vision protection at places at places with different brightness.
 - Their technical specifications conform to Q/HLR enterprise standard.

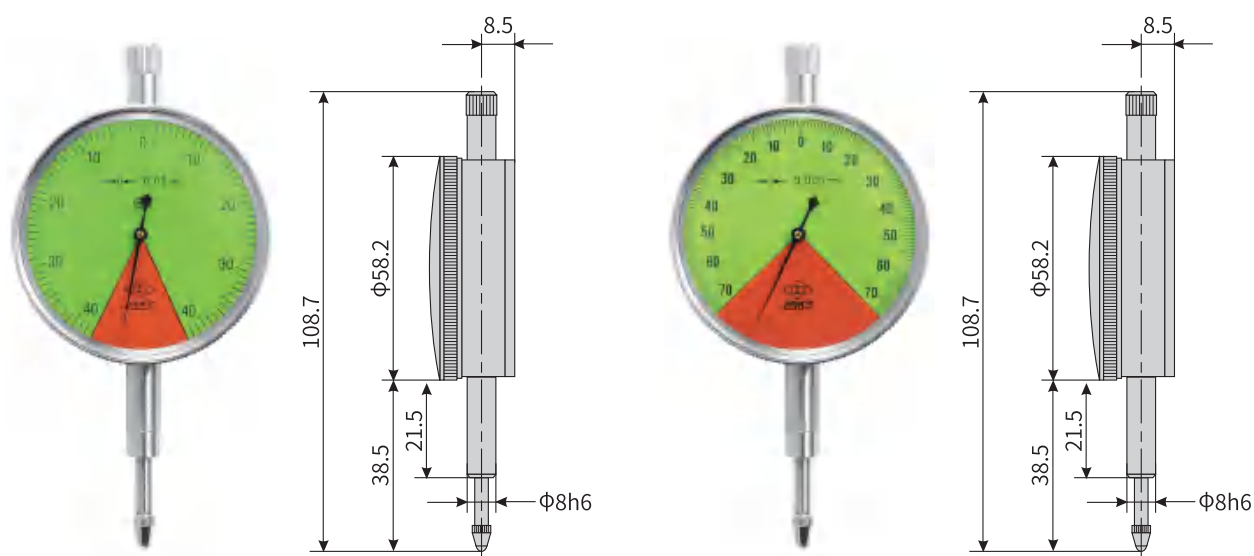

816-01 816-02

单位 (Unit) : mm

编号 Item No.	测量范围 Measuring Range	分度值 Graduation Value	示值误差 Indication Error	质量 Weight(kg)
816-01	±0.4	0.01	0.008	0.117
816-02	±0.07	0.001	0.002	0.220

订货说明：按产品对应的编号订货。

Order Description: order according to the number of products.



双面百分表 818

Double-Sided 0.01mm Dial Indicators 818

- 用于需同时双面读数的场合
- 使用功能与普通百分表相同
- 符合 Q/HLR 企业标准
- Mainly used in the cases where double-sided reading is required at the same time.
- The other functions are the same as those of common dial indicators.
- Their technical specifications conform to Q/HLR enterprise standard.

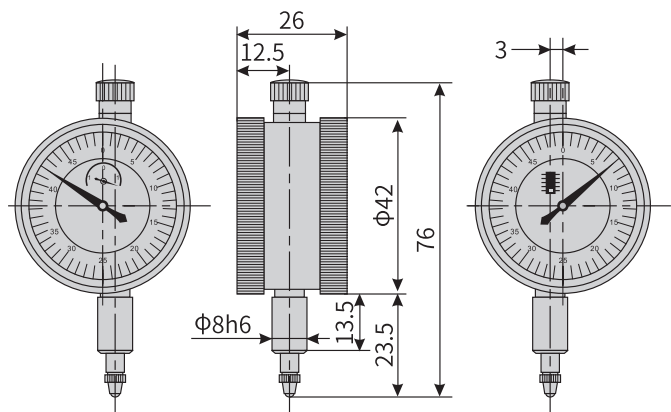

单位 (Unit) : mm

编号 Item No.	测量范围 Measuring Range	分度值 Graduation Value	质量 Weight(kg)
818-01	0-3	0.01	0.113

订货说明：按产品对应的编号订货。

Order Description: order according to the number of products.



深度百分表 819

Depth Dial Indicators 819

- 用于工件深度、台阶等尺寸的测量
- 具有测量可靠、精度高的特点
- 技术要求符合 JB 标准
- The 0.01mm depth dial indicators are suitable for measuring such dimensions of workpieces as depth, step, etc.
- They have the features of reliable measurement and high accuracy.
- Their technical specifications conform to JB standard.

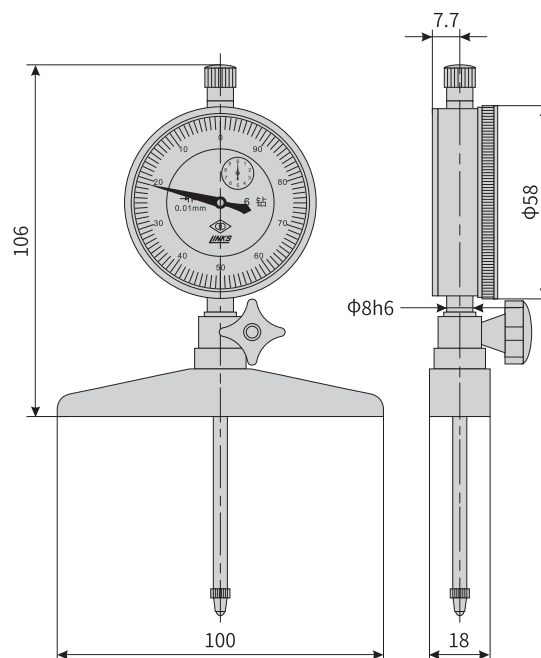

单位 (Unit) : mm

编号 Item No.	测量范围 Measuring Range	分度值 Graduation Value	质量 Weight(kg)
819-01	0-100	0.01	0.40

订货说明：按产品对应的编号订货。

Order Description: order according to the number of products.



磁性表座 822

Magnetic Bases For Dial Indicators 822

- 表架座可水平或垂直吸附在钢铁上
 - 配备 $\phi 6$ 、 $\phi 8$ 两种夹孔的夹头
 - 万向节结构，调整更方便
 - 可进行微动调整
 - 技术要求符合企业标准
- The magnetic bases can be horizontally or vertically attracted onto steel and iron.
 - Two types of clamping holders with the hole diameters of $\phi 6$ and $\phi 8$ are available.
 - The structure of universal joint, so that the adjustment is more convenient.
 - Can be carried out micro adjustment.
 - Technical specifications conform to corporate standard.



单位 (Unit) : mm

编号 Item No.	型号 Modle	工作磁力	座体尺寸	主体尺寸	夹持孔径	质量 Weight(kg)
822-01	CZ-6A	588N (60Kg)	63×50×55	350	$\phi 8.0+0.02$	1.6
822-02	WCZ-6B	588N (60Kg)	63×50×55	290	$\phi 6.5/8.0+0.02$	1.6
822-03	WCE-F	245N (25Kg)	35×30×35	165	$\phi 8.0+0.02$	0.3
822-04	WCE-F1	245N (25Kg)	35×30×35	165	$\phi 8.0+0.02$	0.3
822-05	WCE-C	588N (60Kg)	63×50×55	280	$\phi 8.0+0.02$	1.6
822-06	WCE-D	788N (80Kg)	63×50×55	280	$\phi 8.0+0.02$	1.6
822-07	WCE-8CF	788N (80Kg)	60×50×55	340	$\phi 8.0+0.02$	1.7



测厚规 823

Thickness Gauges 823

- 主要用于测量纸张、皮革、橡胶、织物及金属板、玻璃等的厚度
- 测厚规的测力可根据用户的要求制造
- Thickness gauges are mainly used for measuring thickness of paper, leather, rubber, fabric, metal plate and glass, etc.
- Measuring forces of thickness gauges can be produced according to the customers' requirements.

823-01

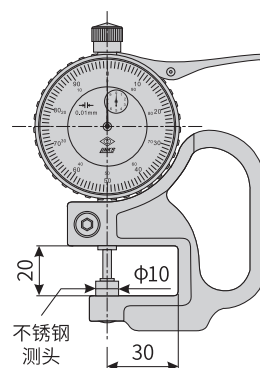

823-03

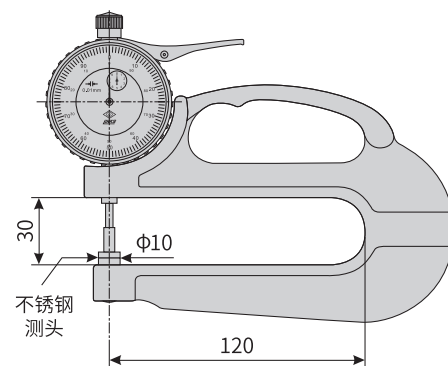

单位 (Unit) : mm

编号 Item No.	测量范围 Measuring Range	分度值 Graduation Value	指示表 Indicator	跨度 Span	质量 Weight(kg)	备注 Remarks
823-01	0-10	0.01	配普通表	30	0.26	标准型测头组合 Standard type contact points
823-02	0-10	0.01	配普通表	60	0.33	标准型测头组合 Standard type contact points
823-03	0-10	0.01	配普通表	120	0.46	标准型测头组合 Standard type contact points
823-04	0-10	0.01	配普通表	200	0.62	标准型测头组合 Standard type contact points
823-05	0-10	0.01	配普通表	300	0.86	标准型测头组合 Standard type contact points
823-06	0-20	0.01	配普通表	60	0.27	标准型测头组合 Standard type contact points
823-07	0-30	0.01	配普通表	305	0.80	标准型测头组合 Standard type contact points



测厚规 823A

Thickness Gauges 823A

- 主要用于测量纸张、皮革、橡胶、织物及金属板、玻璃等的厚度
- 测厚规的测力可根据用户的要求制造
- 防震结构表头
- Thickness gauges are mainly used for measuring thickness of paper, leather, rubber, fabric, metal plate and glass, etc.
- Measuring forces of thickness gauges can be produced according to the customers' requirements.
- Shockproof dial.

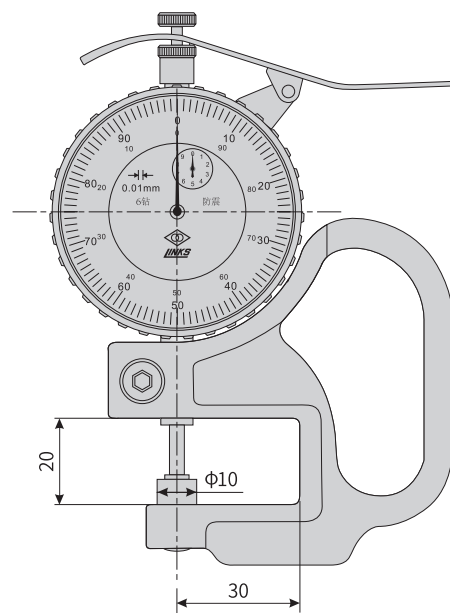

单位 (Unit) : mm

编号 Item No.	测量范围 Measuring Range	分度值 Graduation Value	指示表 Indicator	跨度 Span	质量 Weight(kg)	备注 Remarks
823A-01	0-10	0.01	防震表头	30	0.26	标准型测头组合 Standard type contact points
823A-02	0-10	0.01	防震表头	60	0.33	标准型测头组合 Standard type contact points
823A-03	0-10	0.01	防震表头	120	0.46	标准型测头组合 Standard type contact points
823A-04	0-10	0.01	防震表头	200	0.62	标准型测头组合 Standard type contact points
823A-05	0-10	0.01	防震表头	300	0.86	标准型测头组合 Standard type contact points
823A-06	0-20	0.01	防震表头	60	0.27	标准型测头组合 Standard type contact points
823A-07	0-30	0.01	防震表头	305	0.80	标准型测头组合 Standard type contact points



公制带表外卡规 824

Metric Outside Dial Caliper Gauges 824

- 带表外卡规是一种实用性较强的专用精密量具
- 可用于测量外径、环形槽底外径、板厚等尺寸及其偏差
- The outside dial caliper gauges are practical and precise measuring tools.
- For measuring dimension and deviation of outside diameter, outside diameter of circular grooves, plate thickness, etc.

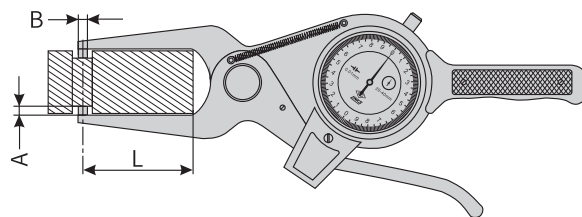

单位 (Unit) : mm

编号 Item No.	测量范围 Measuring Range	分度值 Graduation Value	L	A	B	质量 Weight(kg)
824-01	0-20	0.01	60	6	φ3	0.46
824-02	20-40	0.01	60	6	φ3	0.48
824-03	40-60	0.01	55	6	φ3	0.48
824-04	60-80	0.01	55	6	φ3	0.48
824-05	80-100	0.01	55	6	φ3	0.49

订货说明：按产品对应的编号订货。

Order Description: order according to the number of products.



公制带表外卡规 824A

Metric Outside Dial Caliper Gauges 824A

- 带表外卡规是一种实用性较强的专用精密量具
- 可用于测量外径、环形槽底外径、板厚等尺寸及其偏差
- 防震结构表头
- The outside dial caliper gauges are practical and precise measuring tools.
- For measuring dimension and deviation of outside diameter, outside diameter of circular grooves, plate thickness, etc.
- Shockproof dial.

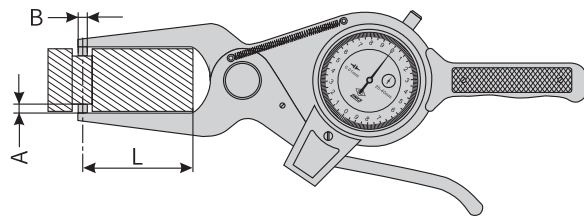

单位 (Unit) : mm

编号 Item No.	测量范围 Measuring Range	分度值 Graduation Value	L	A	B	质量 Weight(kg)
824A-01	0-20	0.01	60	6	Φ3	0.891
824A-02	20-40	0.01	60	6	Φ3	0.920
824A-03	40-60	0.01	55	6	Φ3	0.914
824A-04	60-80	0.01	55	6	Φ3	0.954
824A-05	80-100	0.01	55	6	Φ3	1.126
824A-06	100-120	0.01	95	10	Φ3.2	1.145
824A-07	120-140	0.01	95	10	Φ3.2	1.202
824A-08	140-160	0.01	95	10	Φ3.2	1.593
824A-09	160-180	0.01	95	10	Φ3.2	1.616
824A-10	180-200	0.01	95	10	Φ3.2	1.614
824A-11	200-220	0.01	160	10	Φ3.2	1.788
824A-12	220-240	0.01	160	10	Φ3.2	1.745
824A-13	240-260	0.01	180	10	Φ3.2	1.830
824A-14	260-280	0.01	200	10	Φ3.2	2.101
824A-15	280-300	0.01	200	10	Φ3.2	2.109
824A-16	300-320	0.01	220	10	Φ3.2	2.240

订货说明：按产品对应的编号订货。

Order Description: order according to the number of products.



公制带表内卡规 825

Metric Outside Dial Caliper Gauges 825

- 带表内卡规是一种实用性较强的专用精密量具
- 可用于测量内径、深孔沟槽直径
- 检测直观
- The inside dial caliper gauges are practical and precise measuring tools.
- For measuring dimension and deviation of Inside diameter, diameter of deep hole flute.
- Direct reading.

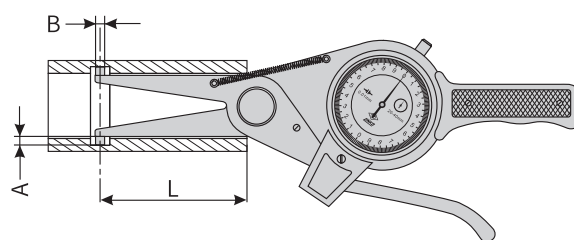

单位 (Unit) : mm

编号 Item No.	测量范围 Measuring Range	分度值 Graduation Value	L	A	B	质量 Weight(kg)
825-01	15-35	0.01	50	3	Φ3	0.445
825-02	35-55	0.01	80	6	Φ3	0.465
825-03	55-75	0.01	90	8	Φ3	0.465
825-04	75-95	0.01	100	8	Φ3	0.475
825-05	95-115	0.01	150	10	Φ3	0.575
825-06	115-135	0.01	150	10	Φ3	0.585
825-07	135-155	0.01	160	10	Φ3	0.595
825-08	155-175	0.01	160	10	Φ3	0.605
825-09	175-195	0.01	160	10	Φ3	0.615
825-10	195-215	0.01	170	10	Φ3	0.635

订货说明：按产品对应的编号订货。

Order Description: order according to the number of products.



公制带表内卡规 825A

Metric Outside Dial Caliper Gauges 825A

- 带表内卡规是一种实用性较强的专用精密量具
- 可用于测量内径、深孔沟槽直径
- 检测直观
- 防震结构表头

- The inside dial caliper gauges are practical and precise measuring tools.
- For measuring dimension and deviation of Inside diameter, diameter of deep hole flute.
- Direct reading.
- Shockproof dial.

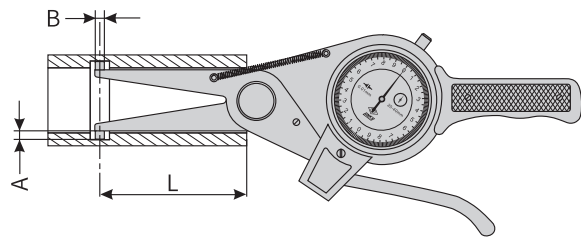

单位 (Unit) : mm

编号 Item No.	测量范围 Measuring Range	分度值 Graduation Value	L	A	B	质量 Weight(kg)
825A-01	15-35	0.01	50	3	φ3	0.891
825A-02	35-55	0.01	80	6	φ3	0.920
825A-03	55-75	0.01	90	8	φ3	0.914
825A-04	75-95	0.01	100	8	φ3	0.954
825A-05	95-115	0.01	150	10	φ3.2	1.126
825A-06	115-135	0.01	150	10	φ3.2	1.145
825A-07	135-155	0.01	160	10	φ3.2	1.202
825A-08	155-175	0.01	160	10	φ3.2	1.593
825A-09	175-195	0.01	160	10	φ3.2	1.616
825A-10	195-215	0.01	160	10	φ3.2	1.614
825A-11	215-235	0.01	160	10	φ3.2	1.788
825A-12	235-255	0.01	160	10	φ3.2	1.745
825A-13	255-275	0.01	180	10	φ3.2	1.830
825A-14	275-295	0.01	200	10	φ3.2	2.101
825A-15	295-315	0.01	200	10	φ3.2	2.109
825A-16	315-335	0.01	220	10	φ3.2	2.240



量块 901 902

Gauge Blocks 901 902

- 量块是长度计量的实物基准
- 量块的各项精度指标符合国家标准 GB/T6093 及国际标准
- 也可按 DIN861, ASME B89.1.9 标准供货
- The gauge blocks are length measuring standards.They are used for length measurement .
- The accuracies conform to GB/T6093 and ISO standards.
- Gauge blocks with DIN861,ASME B89.1.9 standards can also be provided.

量块矩形 Rectangular Gauge Block

注 (Note) : $ln \leq 10\text{mm}$, $a=30$; $ln > 10\text{mm}$, $a=35$

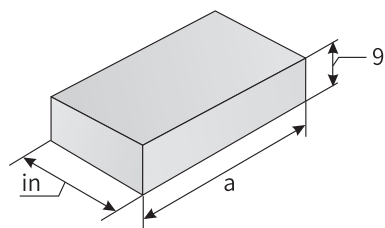

量块成套表 Gauge Block Set Table

ISO 3650

单位 (Unit) : mm

编号 Item No.	总块数 Pcs.per set	级别 Class	标称长度系列 Series of nominal size	间隔 Step	块数 Block sin set	质量 Weight(kg)
901-01	91*	0, k, 1, 2	0.5, 1.0		2	1.843
			1.001, 1.002, 1.003... 1.009	0.001	9	
			1.01, 1.02, 1.03... 1.49	0.01	49	
			1.5, 1.6, 1.7... 1.9	0.1	5	
			2.0, 2.5, 3.0... 9.5	0.5	16	
			10, 20, 30... 100	10	10	
901-02	83*	0, k, 1, 2 (3)	0.5, 1.0, 1.005		3	1.764
			1.01, 1.02, 1.03... 1.49	0.01	49	
			1.5, 1.6, 1.7... 1.9	0.1	5	
			2.0, 2.5, 3.0... 9.5	0.5	16	
			10, 20, 30... 100	10	10	



量块成套表 Gauge Block Set Table

ISO 3650

单位 (Unit) : mm

编号 Item No.	总块数 Pcs.per set	级别 Class	标称长度系列 Series of nominal size	间隔 Step	块数 Block sin set	质量 Weight(kg)
901-03	46*	0, k, 1, 2 (3)	1. 0		1	1. 580
			1. 001, 1. 002, 1. 003. 1. 009	0. 001	9	
			1. 01, 1. 02, 1. 03. 1. 09	0. 01	9	
			1. 1, 1. 2, 1. 3. 1. 9	0. 1	9	
			2, 3, 4. 9	1	8	
			10, 20, 30. 100	10	10	
901-04	38*	0, k, 1, 2 (3)	1. 0, 1. 005		2	1. 563
			1. 01, 1. 02, 1. 03. 1. 09	0. 01	9	
			1. 1, 1. 2, 1. 3. 1. 9	0. 1	9	
			2, 3, 4. 9	1	8	
			10, 20, 30. 100	10	10	
901-05	10-	0, 1	0. 991, 0. 992, 0. 993. 1	0. 001	10	0. 021
901-06	10+	0, 1	1, 1. 001, 1. 002. 1. 009	0. 001	10	0. 021
901-07	8	0, 1, 2(3)	125, 150, 175, 200, 250, 300, 400, 500		8	5. 020
901-08	5	0, 1, 2	600, 700, 800, 900, 1000		5	9. 780

DIN 861

单位 (Unit) : mm

编号 Item No.	总块数 Pcs.per set	级别 Class	标称长度系列 Series of nominal size	间隔 Step	块数 Block sin set	质量 Weight(kg)
901-09	103*	0, k, 1, 2	1. 005;		1	2. 165
			1. 01; 1. 02; 1. 03. 1. 49	0. 01	49	
			0. 5; 1; 1. 5; 24. 5	0. 5	49	
			25, 50, 75, 100	25	4	
901-10	87*	0, k, 1, 2	1. 001, 1. 002, 1. 003. 1. 009	0. 001	9	1. 780
			1. 01, 1. 02, 1. 03. 1. 49	0. 01	49	
			0. 5, 1, 1. 5. 9. 5	0. 5	19	
			10, 20, 30. 100	10	10	



DIN 861

单位 (Unit) : mm

编号 Item No.	总块数 Pcs.per set	级别 Class	标称长度系列 Series of nominal size	间隔 Step	块数 Block sin set	质量 Weight(kg)
901-11	47*	0, k, 1, 2	1. 005		1	1. 515
			1. 01, 1. 02, 1. 03. 1. 19	0. 01	19	
			1. 2, 1. 3, 1. 4. 1. 9	0. 1	8	
			1, 2, 3, 9	1	9	
			10, 20, 30. 100	10	10	
901-12	32*	0, k, 1, 2	1. 005		1	0. 412
			1. 01, 1. 02, 1. 03. 1. 09	0. 01	9	
			1. 10, 1. 20, 1. 30. 1. 90	0. 1	9	
			1, 2, 3, 9	1	9	
			10, 20, 30, 50		4	

ASME B89.1.9

单位 (Unit) : mm

编号 Item No.	总块数 Pcs.per set	级别 Class	公称尺寸系列 Series of nominal size	间隔 Step	块数 Block sin set	质量 Weight(kg)
901-13	112	0 级 AS-1 级 * AS-2 级 *	0. 5, 1. 0, 1. 0005		3	2. 317
			1. 001; 1. 002; 1. 003. . . . 1. 009	0. 001	9	
			1. 01; 1. 02; 1. 03. 1. 49	0. 01	49	
			1. 5; 2. 0; 2. 5. 25	0. 5	48	
			50, 75, 100	25	3	

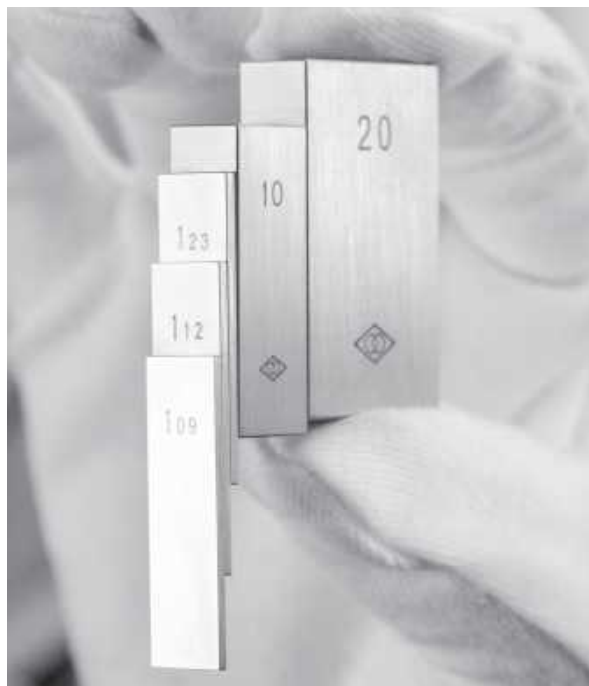

千分尺检定专用量块 903

Special Gauge Blocks For Testing Micrometers 903

- 千分尺检定专用量块是一种长度计量基准
- 主要用于千分尺示值误差的检定，精度分为 0、1、2 级
- 符合国家标准及国际标准
- The special gauge blocks for testing micrometers are length measuring standards.
- Mainly used for testing the indication error of micrometers, with grade 0, 1, 2 accuracies.
- It conforms to GB and ISO standards.



单位 (Unit) : mm

编号 Item No.	总块数 Pcs.per set	级别 Class	尺寸系列 Size series	质量 Weight(kg)
903-01	10	0, 1, 2	2.5, 5.1, 7.7, 10.3, 12.9, 15, 17.6, 20.2, 22.8, 25	0.3357
903-02	10	0, 1, 2	27.5, 30.1, 32.7, 35.3, 37.9, 40, 42.6, 45.2, 47.8, 50	0.956
903-03	10	0, 1, 2	52.5, 55.1, 57.7, 60.3, 62.9, 65, 67.6, 70.2, 72.8, 75	1.560
903-04	10	0, 1, 2	77.5, 80.1, 82.7, 85.3, 87.9, 90, 92.6, 95.2, 97.8, 100	2.194
903-05	20	0, 1, 2(3)	5.12, 10.24, 15.36, 21.5, 25 30.12, 35.24, 40.36, 46.5, 50 55.12, 60.24, 65.36, 71.5, 75 80.12, 85.24, 90.36, 96.5, 100	2.598

订货说明：按产品对应的编号和级别订货。

Order Description: Please specify product item no. and grade for orders.



游标卡尺检定专用量块 904

Special Gauge Blocks For Testing Vernier Calipers 904

- 游标卡尺检定专用量块是一种长度计量基准
- 主要用于游标卡尺示值误差的检定
- 精度分为0、1、2、3级，符合国家标准及国际标准。
- The special gauge blocks for testing vernier calipers are length measuring standards.
- Mainly used for testing the indication error of vernier calipers.
- Grade 0,1,2,3 conforms to GB and ISO standards.



单位 (Unit) : mm

编号 Item No.	总块数 Pcs.per set	级别 Class	尺寸系列 Size series	质量 Weight(kg)
904-01	12	0, 1, 2(3)	10, 20, 20, 41.2, 51.2, 81.5, 101.2, 121.5, 121.8, 191.8, 201.5, 291.8	0.727
904-02	6	2, 3	10, 20, 20, 41.2, 81.5, 121.8	0.727
904-03	6	2, 3	51.2, 101.2, 121.5, 191.8, 201.5, 291.8	2.359
904-04	6	2, 3	101.2, 200, 291.5, 375, 451.8, 490	4.692
904-05	6	2, 3	201.2, 400, 581.5, 750, 901.8, 990	9.397
904-06	7	2, 3	41.2, 51.2, 92.5, 101.2, 123.8, 192.5, 293.8	2.811

订货说明：按产品对应的编号和级别订货。

Order Description: Please specify product item no. and grade for orders.



数显卡尺检定专用量块 905

Special Gauge Blocks For Testing Digital Calipers 905

- 数显卡尺检定专用量块是一种长度计量基准
- 用于数显卡尺示值误差的检定
- 精度分为 2、3 级，符合国家标准及国际标准
- The special gauge blocks for testing digital calipers are length measuring standards.
- Mainly used for testing the indication error of digital calipers.
- Grade 2,3 conforms to GB and ISO standards.



单位 (Unit) : mm

编号 Item No.	规格 Specification	总块数 Pcs.per set	级别 Class	尺寸系列 Size series	间隔 Step	块数 Blocks in set	质量 Weight(kg)	备注 Remarks
905-01	0-150	20	2、3	5, 10, 15, 20, 50	5	10	3.247	数显卡尺 检定专用量块 Gauge blocks for digital calipers
				60, 70, 80, 90, 150	10	10	3.247	
905-02	0-200	20	2、3	10, 20, 30, 40, 200	10	20	5.152	
905-03	0-300	20	2、3	15, 30, 45, 60, 300	15	20	7.732	
905-11	0-150	8	2、3	11, 32, 53, 74, 95, 110, 130, 150		8	1.507	
905-12	0-200	8	2、3	25, 54, 83, 102, 131, 160, 180, 200		8	2.272	
905-13	0-300	8	2、3	35, 74, 113, 152, 171, 220, 260, 300		8	3.252	
905-14	0-500	8	2、3	51, 102, 153, 204, 255, 300, 350, 400, 450, 500		10	5.629	



角度量块 906

Angle Gauge Blocks 906

- 角度量块是一种角度计量的实物基准，适用于角度检测和万能角度尺及角度样板的检定
- 符合 GB 标准
- The angle gauge blocks are angle measuring standards used to calibrate bevel protractors.
- It conforms to GB standard.



单位 (Unit) : mm

编号 Item No.	总块数 Pcs.per set	级别 Class	工作角公称值 Nominal angle	间隔 Step	块数 Block sin set	质量 Weight(kg)
906-03	7	1, 2	15° 10' , 30° 20' , 45° 30' , 50°		7	0.496
			60° 40' , 75° 50' , 90° -90° -90° -90°		7	

检测万能角度尺专用

订货说明：按产品对应的编号和级别订货。

Order Description: Please specify product item no. and grade for orders.



刀口尺 909

Straight Edges 909

- 符合 GB 标准

- It conforms to GB standard



单位 (Unit) : mm

编号 Item No.	规格 Specifications	级别 Class	质量 Weight(kg)
909-01	75	0	0.043
909-02	125	0	0.101
909-03	175	0	0.150

订货说明：按产品对应的编号和级别订货。

Order Description: Please specify product item no. and grade for orders.



宽座角尺 910

Wide-Base Angle Squares 910

- 可精确测量工件内角、外角的垂直度偏差
- 符合 GB 标准
- The wide-base angle squares can be used to accurately measure the verticality deviation of the internal angles and external angles of workpieces.
- It conforms to GB standard.



单位 (Unit) : mm

编号 Item No.	规格 Specifications	级别 Class	质量 Weight(kg)
910-01	63×40	1	0.033
910-02	125×80	1	0.257
910-03	200×125	1	0.387
910-04	160×100	1	0.825
910-05	250×160	1	1.053
910-06	315×200	1	2.085
910-07	400×250	1	3.200
910-08	500×315	1	4.500

订货说明：按产品对应的编号和级别订货。

Order Description: Please specify product item no. and grade for orders.



量块夹子 911

Gauge Block Clips 911

- 量块夹子可将 (125-1000)mm 的大量块中的任意两块进行连接
 - 可以将多个量块连接在一起，以及同夹持滑块进行连接，连接后进行精密刻线、测量、检测等
 - 符合 JB 标准
- The gauge block clips manufactured by our company can connect any two pieces of big gauge blocks with the size of 125-1000mm together and connect several pieces of such gauge blocks together.
 - And also connect clamp slides together, to make precision scribing, measurement, testing, etc.
 - It conforms to JB standard.



单位 (Unit) : mm

编号 Item No.	规格 Specifications	单位	备注 Remarks
911	3 件	组	
911	5 件	组	

订货说明：按产品对应的编号和规格订货。

Order Description: order according to the number of products.



螺纹测量用三针 921

Three Wires For Thread Checking 921

- 螺纹测量用三针是每组具有确定的相同公称直径的三个量针
- 以间接法测量螺纹中径
- 符合 GB 标准
- Three wire gauges in a set are with the same defined nominal.
- Diameters to measure pitch diameters.
- It conforms to GB standard.



单位 (Unit) : mm

编号 Item No.	准确度等级 Class	公称直径 D Nominal Dia.	质量 Weight(kg)
921-01	0, 1	0.118	0.000010
	0, 1	0.142	0.000015
	0, 1	0.185	0.000025
	0, 1	0.250	0.000047
	0, 1	0.291	0.000063
	0, 1	0.343	0.000088
	0, 1	0.433	0.000140
	0, 1	0.511	0.000194
	0, 1	0.572	0.000243
	0, 1	0.724	0.000439
	0, 1	0.796	0.000530
	0, 1	0.866	0.000628
	0, 1	1.008	0.000850
	0, 1	1.157	0.001120
	0, 1	1.302	0.001419
	0, 1	1.441	0.001738
	0, 1	1.553	0.002019
	0, 1	1.732	0.002232

单位 (Unit) : mm

编号 Item No.	准确度等级 Class	公称直径 D Nominal Dia.	质量 Weight(kg)
921-01	0, 1	1.833	0.002499
	0, 1	2.050	0.003127
	0, 1	2.311	0.003973
	0, 1	2.595	0.005010
	0, 1	2.886	0.006197
	0, 1	3.106	0.007178
	0, 1	3.177	0.007510
	0, 1	3.550	0.009376
	0, 1	4.120	0.012630
	0, 1	4.400	0.014404
	0, 1	4.773	0.016950
	0, 1	5.150	0.019730
	0, 1	6.212	0.028710

准确度等级 Class	公称直径 D 的尺寸偏差 Nominal dia.deviation	圆度公差 Roundness tolerance
0	±0.25 μm	0.25 μm
1	±0.50 μm	0.50 μm



单位 (Unit) : mm

被测螺纹的螺距 Tested thread pitch				量针公称直径 D Nominal dia. of pin gauge D
公制螺纹 (螺距) Metric thread (pitch)	英制螺纹 (每英寸上的牙数) Inch thread (number of teech per inch)		梯形螺纹 (导程) Trapezoidal thread (lead)	
	55°	60°		
0.2				0.118
(0.225)				0.118
0.25				0.142
0.3				0.185
		80		0.185
0.35		72		0.185
0.4		64		0.25
0.45		56		0.25
0.5		48		0.291
0.6				0.343
		44		0.343
	40	40		0.343
0.7				0.433
0.75		36		0.433
0.8	32	32		0.433
	28	28		0.511
1		27		0.572
	26	26		0.572
	24	24		0.572
1.25	22, 20, 19	20		0.724
	18	18		0.796
1.5	16	16		0.866
1.75	14	14		1.008
			2	1.008
2	12	13		1.157
		12		1.157
	11	11 1/2	2✘	1.302
		11		1.302
2.5	10	10		1.441
	9	9	3	1.553
3			3✘	1.732
	8	8		1.833
3.5	7	7 1/2	4	2.050
		7		2.050
4	6	6	4✘	2.311
4.5		5 1/2	5	2.595
5	5	5	5✘	2.886
			6	3.106



单位 (Unit) : mm

被测螺纹的螺距 Tested thread pitch				量针公称直径 D Nominal dia. of pin gauge D
公制螺纹 (螺距) Metric thread(pitch)	英制螺纹 (每英寸上的牙数) Inch thread(number of teech per inch)		梯形螺纹 (导程) Trapezoidal thread (lead)	
	55°	60°		
5.5	4 1/2	4 1/2	6※	3.177
6	4	4		3.550
	3 1/2		8	4.120
	3 1/4		8※	4.400
	3			4.773
	2 7/8、2 3/4		10	5.150
	2 5/8、2 1/2		12	6.212

测量螺纹中径时，建议根据被测螺纹的螺距选用相应公称直径的量针。

It is recommended that to choose corresponding pin gauge of proper nominal diameter according to the tested pitch before measuring.

注 1:

选择量针的公称直径测量单头螺纹中径时，除标有“※”符号的螺距外，由于螺纹牙形半角偏差而产生的测量误差甚小可忽略不计。

注 2:

当用量针测量梯形螺纹中径出现量针表面低于螺纹外径和测量通端梯形螺纹塞规中径时，按带“※”号的相应螺距来选择量针；此时应计入牙形半角偏差对测量结果的影响。

Note 1:

When measuring single-start thread pitch diameters, except from the ones marked with ※, with nominal diameters of pin gauges, the measuring errors result from half-angle thread tooth can be neglected.

Note 2:

When the surface of pin gauges lower than the outer diameters of threads as measuring trapezoidal thread pitch diameters and measuring pitch diameters of GO trapezoidal thread plug gauges, please select proper pin gauges from specification marked with ※. And the half-angle tooth error shall be added in undersuch measuring conditions.

订货说明:

请按其产品编号、直径及等级订货。例：螺纹测量用三针 0.118 1 级，标注为：921-01-0.118/1

Order instruction:

Please specify the item No., diameter and grade information in your order.

For example:

three wires for measuring diameter 0.118 thread of grade 1, please specify 921-01-0.118/1 in your order.



针规 922

Pin Gauges 922

- 针规适用于机械加工中孔径、孔距的测量
- 特别适于弯曲槽宽及模具尺寸的测量
- 可按用户要求生产
- The pin gauges are used to measure hole diameters, hole distance of the thread, etc.
- Especially, they are suitable for curved groove width measurement.
- Manufacture by customers' requests.



单位 (Unit) : mm

编号 Item No.	标称直径 Nominal diameter	精度 Accuracy	长度 length	数量 Quantity	质量 Weight(kg)
922-01	0.1;0.11……0.5	±0.002	50	41	0.005
922-02	0.5;0.51……1.0	±0.002	50	51	0.018
922-03	1.0;1.01……1.5	±0.002	50	51	0.039
922-04	1.5;1.51……2.0	±0.002	50	51	0.068
922-05	2.0;2.01……2.5	±0.002	50	51	0.105
922-06	2.5;2.51……3.0	±0.002	50	51	0.149
922-07	3.0;3.01……3.5	±0.002	50	51	0.202
922-08	3.5;3.51……4.0	±0.002	50	51	0.262
922-09	4.0;4.01……4.5	±0.002	50	51	0.330
922-10	4.5;4.51……5.0	±0.002	50	51	0.405
922-11	5.0;5.01……5.5	±0.002	50	51	0.489
922-12	5.5;5.51……6.0	±0.002	50	51	0.600
922-13	6.0;6.01……6.5	±0.002	50	51	0.700

单位 (Unit) : mm

编号 Item No.	标称直径 Nominal diameter	精度 Accuracy	长度 length	数量 Quantity	质量 Weight(kg)
922-14	6.5;6.51……7.0	±0.002	50	51	0.809
922-15	7.0;7.01……7.5	±0.002	50	51	0.925
922-16	7.5;7.51……8.0	±0.002	50	51	1.050
922-17	8.0;8.01……8.5	±0.002	50	51	1.181
922-18	8.5;8.51……9.0	±0.002	50	51	1.321
922-19	9.0;9.01……9.5	±0.002	50	51	1.469
922-20	9.5;9.51……10.0	±0.002	50	51	1.624
922-21	10.0;10.01……10.5	±0.002	50	51	1.787
922-22	10.5;10.51……11.0	±0.002	50	51	1.958
922-23	11.0;11.01……11.5	±0.002	50	51	2.137
922-24	11.5;11.51……12.0	±0.002	50	51	2.324
922-25	12.0;12.01……12.5	±0.002	50	51	2.518
922-26	12.5;12.51……13.0	±0.002	50	51	2.638

订货说明: 请按其产品编号、直径订货。例: 针规 $\phi 0.5-\phi 1.0$, 标注为: 922-02

Order Description: Please specify item No. and diameter for order. Example: for pin gauge $\phi 0.5-\phi 1.0$, mark with 922-02.



普通螺纹量规 923 924

Common Thread Gauges 923 924

- 普通螺纹量规（螺纹环规、螺纹塞规）适用于检测符合国家标准及国际标准的螺纹制件
- 符合 GB 标准
- The common thread gauges including ring gauges and plug gauges are used to calibrate threaded workpieces by GB and ISO standards.
- It conforms to GB standard.



923 924

单位 (Unit) : mm

编号 Item No.	公称直径 Nominal diameter			螺距 Thread pitch				质量 Weight(kg)	
	第 1 系列 1 series	第 2 系列 2 series	第 3 系列 3 series	粗牙 Coarse	细牙 Fine			环规 Ring gauge	塞规 Plug gauge
923	1			0.25	0.20			0.0031	0.0006
		1.1		0.25	0.20			0.0031	0.0006
	1.2			0.25	0.20			0.0031	0.0006
		1.4		0.30	0.20			0.0033	0.0006
	1.6			0.35	0.20			0.0034	0.0006
		1.8		0.35	0.20			0.0034	0.0007
	2			0.40	0.25			0.0063	0.0006
	924	2.2		0.45	0.25			0.0048	0.0007
		2.5		0.45	0.35			0.0080	0.0007
		3		0.50	0.35			0.0075	0.0008
		3.5	0.60	0.35			0.0074	0.0008	
	4		0.70	0.50			0.0139	0.0010	
		4.5	0.75	0.50			0.0145	0.0017	
	5		0.80	0.50			0.0137	0.0013	



单位 (Unit) : mm

编号 Item No.	公称直径 Nominal diameter			螺距 Thread pitch					质量 Weight(kg)	
	第 1 系列 1 series	第 2 系列 2series	第 3 系列 3series	粗牙 Coarse	细牙 Fine				环规 Ring gauge	塞规 Plug gauge
			5.5		0.50				0.0404	0.0022
6				1.00	0.75	0.50			0.0146	0.0027
		7		1.00	0.75	0.50			0.0396	0.0048
8				1.25	1.00	0.75	0.50		0.0340	0.0046
			9	1.25	1.00	0.75	0.50		0.0385	0.0065
10				1.50	1.25	1.00	0.75	0.50	0.0400	0.0074
			11	1.50	1.00	0.75	0.50		0.0579	0.0112
12				1.75	1.50	1.25	1.00	0.75	0.0715	0.0139
			14	2.00	1.50	1.25	1.00	0.75	0.0805	0.0188
			15		1.50	1.00			0.0853	0.0285
16				2.00	1.50	1.00	0.75	0.50	0.0762	0.0292
			17		1.50	1.00			0.1318	0.0342
			18	2.50	2.00	1.50	1.00	0.75	0.1360	0.0402
20				2.50	2.00	1.50	1.00	0.75	0.1290	0.0580
			22	2.50	2.00	1.50	1.00	0.75	0.1630	0.0630
24				3.00	2.00	1.50	1.00	0.75	0.1800	0.0930
			25		2.00	1.50	1.00		0.1664	0.0776
			26		1.50				0.2491	0.0828
			27	3.00	2.00	1.50	1.00		0.1900	0.1350
923			28		2.00	1.50	1.00		0.2816	0.0938
924			30	3.50	3.00	2.00	1.50	0.75	0.3200	0.1630
			32		2.00	1.50			0.2241	0.1371
			33	3.50	3.00	2.00	1.50	1.00	0.3500	0.2250
			35		1.50				0.3136	0.1583
36				4.00	3.00	2.00	1.50		0.3700	0.2730
			38		1.50				0.2964	0.1815
			39	4.00	3.00	2.00	1.50		0.4300	0.3360
			40		3.00	2.00	1.50		0.2905	0.2853
42				4.50	4.00	3.00	2.00	1.50	0.6300	0.4510
			45	4.50	4.00	3.00	2.00	1.50	0.6700	0.4890
48				5.00	4.00	3.00	2.00	1.50	0.8000	0.5750
			50		3.00	2.00	1.50		0.4224	0.3441
			52	5.00	4.00	3.00	2.00	1.50	0.9000	0.6670
			55		4.00	3.00	2.00	1.50	0.6189	0.4949
56				5.50	4.00	3.00	2.00	1.50	1.1000	0.9090
			58		4.00	3.00	2.00	1.50	0.6000	0.5464
			60	5.50	4.00	3.00	2.00	1.50	1.3000	1.0390
			62		4.00	3.00	2.00	1.50	0.7704	0.6457
64				6.00	4.00	3.00	2.00	1.50	0.8775	0.7556
			65		4.00	3.00	2.00	1.50	0.7381	0.7037



单位 (Unit) : mm

编号 Item No.	公称直径 Nominal diameter			螺距 Thread pitch					质量 Weight(kg)		
	第 1 系列 1 series	第 2 系列 2 series	第 3 系列 3 series	粗牙 Coarse	细牙 Fine				环规 Ring gauge	塞规 Plug gauge	
		68		6.00	4.00	3.00	2.00	1.50		1.0680	0.8464
			70		6.00	4.00	3.00	2.00	1.50	1.0153	0.8939
	72				6.00	4.00	3.00	2.00	1.50	0.9240	0.8499
			75		4.00	3.00	2.00	1.50		0.8865	0.9172
		76			6.00	4.00	3.00	2.00	1.50	1.3235	1.0450
			78		2.00					0.8474	0.9754
	80				6.00	4.00	3.00	2.00	1.50	1.2445	1.1527
			82		2.00					1.2192	1.0851
		85			6.00	4.00	3.00	2.00		1.6574	1.2968
	90				6.00	4.00	3.00	2.00		1.5462	1.4468
		95			6.00	4.00	3.00	2.00		2.2098	1.6071
	100				6.00	4.00	3.00	2.00		2.0856	1.7418
		105			6.00	4.00	3.00	2.00		1.7500	1.7500
923	110				6.00	4.00	3.00	2.00		3.5600	3.5600
924		115			6.00	4.00	3.00	2.00		3.0800	3.0800
		120			6.00	4.00	3.00	2.00		3.5400	3.5400
	125				6.00	4.00	3.00	2.00		3.6900	3.6900
		130			6.00	4.00	3.00	2.00		4.8500	4.8500
		135			6.00	4.00	3.00	2.00		3.3244	3.9030
	140				6.00	4.00	3.00	2.00		4.6000	4.9000
		145			6.00	4.00	3.00	2.00		2.7375	4.7003
		150			6.00	4.00	3.00	2.00		4.3283	5.7790
		155			6.00	4.00	3.00			5.0230	6.2697
	160				6.00	4.00	3.00			4.7352	6.7767
		165			6.00	4.00	3.00			5.8288	7.3000
		170			6.00	4.00	3.00			5.4354	7.8395
		175			6.00	4.00	3.00			6.5152	8.3953
	180				6.00	4.00	3.00			6.0980	8.9674

订货说明:

请按产品编号被测工件的螺纹直径、螺距及公差带级别订货。

例: 工件外螺纹 M10×1-6g 用环规, 标注为: 923-M10×1-6g 工件内螺纹 M10×1-6H 用塞规, 标注为: 924-M10×1-6H。

我厂可提供 3h4h、4h、5h4h、6e、6f、5g6g、6g、7g6g、5h6h、6h、7h6h、8g、8h 级的环规和 4H、4H5H、5H6H、5G、6G、7G、5H、6H、7H 级的塞规。

Order instruction:

Please specify the item number diameter, pitch and class of the thread in your order.

Example: the ring gauges used for checking outside thread M10×1-6g, please specify 923-M10×1-6g and the plug gauge used for checking inside thread M10×1-6H, please specify 924-M10×1-6H.

We can provide ring gauges of class 3h4h, 4h, 5h4h, 6e, 6f, 5g6g, 6g, 7g6g, 5h6h, 6h, 7h6h, 8g, 8h and plug gauge of class 4H, 4H5H, 5H6H, 5G, 6G, 7G, 5H, 6H and 7H.



美标统一螺纹量规 925 926

Ansi Standard Thread Gauges 925 926

- 美标统一螺纹量规是适用于检验美国国家标准和美国联邦螺纹标准的螺纹制件的螺纹量规
- 符合 JB 标准
- ANSI standard thread gauges are applied to examine threaded workpieces produced by American national standards as well as American federal standards.
- It conforms to JB standard.



单位 (Unit) : inch

编号 Item No.	公称直径 或代号 Nominal dia or Code	N(牙数 / 英寸) Tooth No.										质量 Weight(kg)								
		UNC	UNF	UNEF	UN					UNS					环规 Ring gauge	塞规 Plug gauge				
	No. 0		80														0.0120	0.0006		
	No. 1	64	72															0.0119	0.0007	
	No. 2	56	64															0.0119	0.0007	
	No. 3	48	56															0.0126	0.0007	
	No. 4	40	48															0.0141	0.0008	
	No. 5	40	44															0.0140	0.0008	
	No. 6	32	40															0.0155	0.0021	
	No. 8	32	36															0.0153	0.0023	
925	No. 10	24	32									28	36	40	48	56		0.0151	0.0024	
926	No. 12	24	38	32									36	40	48	56		0.0325	0.0026	
	1/4	20	28	32								24	27	36	40	48	56	0.0322	0.0030	
	5/16	18	24	32				20	28			27	36	40	48			0.0422	0.0063	
	3/8	16	24	32				20	28			18	27	36	40			0.0381	0.0076	
	7/16	14	20	28				16		32	18	24		36	40			0.0706	0.0142	
	1/2	13	20	28				16		32	12	14	18	24	27	36	40	0.0770	0.0169	
	9/16	12	18	24				16	20	28	32		14		27	36	40	0.0667	0.0181	
	5/8	11	18	24				12	16	20	28	32		14		27	36	40	0.1063	0.0331
	11/16			24				12	16	20	28	32						0.0923	0.0345	



单位 (Unit) : inch

编号 Item No.	公称直径 或代号 Nominal dia or Code	N(牙数 / 英寸) Tooth No.														质量 Weight(kg)					
		UNC	UNF	UNEF	UN						UNS						环规 Ring gauge	塞规 Plug gauge			
	3/4	10	16	20				12			28	32		14	18	24	27	36	40	0.1109	0.0534
	13/16			20				12	16		28	32								0.1388	0.0525
	7/8	9	14	20				12	16		28	32	10		18	24	27	36	40	0.1759	0.0616
	15/16			20				12	16		28	32								0.1240	0.0601
	1	8	12	20					16		28	32	10	14	18	24	27	36	40	0.2514	0.0710
	1 1/16			18			8	12	16	20	28									0.2558	0.0762
	1 1/8	7	12	18			8		16	20	28		10	14		24				0.2492	0.0818
	1 3/16			18			8	12	16	20	28									0.2320	0.0854
	1 1/4	7	12	18			8		16	20	28		6	10	14	24				0.2309	0.1334
	1 5/16			18			8	12	16	20	28									0.3103	0.1317
	1 3/8	6	12	18			8		16	20	28			10	14	24				0.3406	0.1617
	1 7/16			18		6	8	12	16	20	28									0.2937	0.1458
	1 1/2	6	12	18			8		16	20	28			10	14	24				0.3018	0.1533
	1 9/16			18		6	8	12	16	20	28									0.3109	0.1915
	1 5/8			18		6	8	12	16	20	28			10	14	24				0.4709	0.1868
	1 11/16			18		6	8	12	16	20	28									0.4786	0.2167
	1 3/4	5				6	8	12	16	20	28			10	14	18				0.4670	0.2235
	1 13/16					6	8	12	16	20	28									0.4549	0.2431
925	1 7/8					6	8	12	16	20	28			10	14	18				0.4424	0.2531
926	1 15/16					6	8	12	16	20	28									0.4295	0.2689
	2	4.5				6	8	12	16	20	28			10	14	18				0.6335	0.3031
	2 1/16															16				0.5943	0.2707
	2 1/8					6	8	12	16	20										0.6289	0.3312
	2 3/16															16				0.5673	0.2937
	2 1/4	4.5				6	8	12	16	20				10	14	18				0.5991	0.3612
	2 5/16															16				0.5386	0.3180
	2 3/8					6	8	12	16	20										0.7884	0.3928
	2 7/16															16				0.7134	0.3964
	2 1/2	4				6	8	12	16	20				10	14	18				0.6723	0.4326
	2 5/8				4	6	8	12	16	20										1.0794	0.6819
	2 3/4	4				6	8	12	16	20				10	14	18				0.6833	0.5510
	2 7/8				4	6	8	12	16	20										1.3653	0.7929
	3	4				6	8	12	16	20				10	14	18				1.0476	0.7215
	3 1/8				4	6	8	12	16											1.2445	0.9143
	3 1/4	4				6	8	12	16					10	14	18				1.3987	0.8242
	3 3/8				4	6	8	12	16											1.2020	0.7618
	3 1/2	4				6	8	12	16					10	14	18				1.2847	0.9352
	3 5/8				4	6	8	12	16											1.4832	1.1882
	3 3/4	4				6	8	12	16					10	14	18				1.6157	0.9094
	3 7/8				4	6	8	12	16											2.1032	1.3407



单位 (Unit) : inch

编号 Item No.	公称直径 或代号 Nominal dia or Code	N(牙数 / 英寸) Tooth No.												质量 Weight(kg)					
		UNC	UNF	UNEF	UN						UNS						环规 Ring gauge	塞规 Plug gauge	
	4	4				6	8	12	16					10	14			2.3483	1.1824
	4 1/8				4	6	8	12	16									2.5079	0.8977
	4 1/4				4	6	8	12	16					10	14			2.1863	0.9221
	4 3/8				4	6	8	12	16									2.8023	1.1228
	4 1/2				4	6	8	12	16					10	14			2.4482	1.0883
	4 5/8				4	6	8	12	16									2.6082	1.3153
	4 3/4				4	6	8	12	16					10	14			2.9972	1.3298
925	4 7/8				4	6	8	12	16									2.9079	1.5888
926	5				4	6	8	12	16					10	14			2.7858	1.5249
	5 1/8				4	6	8	12	16									3.8094	1.8130
	5 1/4				4	6	8	12	16					10	14			3.0954	1.7300
	5 3/8				4	6	8	12	16									3.2697	2.0485
	5 1/2				4	6	8	12	16					10	14			3.1226	1.9453
	5 5/8				4	6	8	12	16									3.0957	1.9390
	5 3/4				4	6	8	12	16					10	14			3.2920	2.1707
	5 7/8				4	6	8	12	16									3.5281	2.5537
	6				4	6	8	12	16					10	14			3.7503	2.4063

订货说明:

请按产品编号直径、每寸牙数和系列代号的产品编号及螺纹精度等级订货。我厂可提供 1A、2A、3A 级的环规和 1B、2B、3B 级的塞规。

例如:

工件外螺纹 2 1/4-12UN-2A 用环规, 标注为: 925-2 1/4-12UN-2A

工件内螺纹 2 1/4-12UN-2B 用塞规, 标注为: 926-2 1/4-12UN-2B

Order instruction:

please specify the item number diameter, teeth per inch, item number and accuracy class in your order .We can provide ring gauges in class 1A,2A,3A and plug gauges in class 1B,2B and 3B.

E.g.:

ring gauge 2 1/4-12UN-2A,specify 925-2 1/4-12UN-2A and plug gauge 2 1/4-12UN-2B, specify 926-2 1/4-12UN-2B.



莫氏圆锥量规 927 928

Morse Taper Gauges 927 928

- 莫氏圆锥量规用于检查机床与工具圆锥孔和圆锥柄的锥度和尺寸的正确性
- 莫氏量规分 A 型不带扁尾和 B 型带扁尾两种型式，精度等级分为 1、2、3 级
- 符合 GB 标准
- The morse taper gauges are used for checking the Morse taper of spindles of machine tools apered shanks of cutting tools and arbors ,etc.
- They are divided into type A(those without flat tail)and type B(those with flat tail).Three accuracy classes are class 1、 class 2、 class3.
- It conforms to GB standard.



927 928



单位 (Unit) : mm

单位 (Unit) : mm

编号 Item No.	规格 Specifications	锥度值 Taper	质量 Weight(kg)	备注 Remarks
927-01	0	1:19.212	0.058	不带扁尾
927-02	1	1:20.047	0.110	莫氏圆锥
927-03	2	1:20.020	0.240	工作环规
927-04	3	1:19.922	0.450	A 型
927-05	4	1:19.254	0.830	MORSE TAPER WORKING RING
927-06	5	1:19.002	2.100	GAUGES
927-07	6	1:19.180	5.300	WITHOUT FLAT TAIL, TYPE A

编号 Item No.	规格 Specifications	锥度值 Taper	质量 Weight(kg)	备注 Remarks
928-01	0	1:19.212	0.054	不带扁尾
928-02	1	1:20.047	0.104	莫氏圆锥
928-03	2	1:20.020	0.251	工作塞规
928-04	3	1:19.922	0.499	A 型
928-05	4	1:19.254	0.921	MORSE TAPER WORKING PLUG
928-06	5	1:19.002	2.100	GAUGES
928-07	6	1:19.180	5.000	WITHOUT FLAT TAIL, TYPE A

订货说明：请按产品名称、规格的编号订货，并注明级别。

例：不带扁尾莫氏圆锥工作环规 0#2 级，标注为：927-01-2。不带扁尾莫氏圆锥工作塞规 0#2 级，标注为：928-01-2

Order Description: Please mark name of the product,item No.and specifications for order.Please also mark the class.
Example:for Morse taper ring gauge without flat tail,0# class 2, mark with 927-01-2 and for Morse taper plug gauge without flat tail 0# class 2, mark with 928-01-2.



莫氏圆锥量规 929 930

Morse Taper Gauges 929 930

- 莫氏圆锥量规用于检查机床与工具圆锥孔和圆锥柄的锥度和尺寸的正确性
- 莫氏量规分 A 型不带扁尾和 B 型带扁尾两种型式，精度等级分为 1、2、3 级
- 符合 GB 标准
- The morse taper gauges are used for checking the Morse taper of spindles of machine tools tapered shanks of cutting tools and arbors ,etc.
- They are divided into type A(those without flat tail)and type B(those with flat tail).Three accuracy classes are class 1、 class 2、 class3.
- It conforms to GB standard.



929 930



单位 (Unit) : mm

单位 (Unit) : mm

编号 Item No.	规格 Specifications	锥度值 Taper	质量 Weight(kg)	备注 Remarks
929-01	0	1:19.212	0.080	带扁尾
929-02	1	1:20.047	0.140	莫氏圆锥
929-03	2	1:20.020	0.260	工作环规
929-04	3	1:19.922	0.460	B 型
929-05	4	1:19.254	0.830	MORSE TAPER
929-06	5	1:19.002	2.030	WORKING RING
929-07	6	1:19.180	5.400	GAUGES
				WITH FLAT
				TAIL, TYPE B

编号 Item No.	规格 Specifications	锥度值 Taper	质量 Weight(kg)	备注 Remarks
930-01	0	1:19.212	0.050	带扁尾
930-02	1	1:20.047	0.106	莫氏圆锥
930-03	2	1:20.020	0.260	工作塞规
930-04	3	1:19.922	0.510	B 型
930-05	4	1:19.254	0.960	MORSE TAPER
930-06	5	1:19.002	2.200	WORKING PLUG
930-07	6	1:19.180	4.900	GAUGES
				WITH FLAT
				TAIL, TYPE B

订货说明：请按产品名称、规格的编号订货，并注明级别。

例：带扁尾莫氏圆锥工作环规 0#2 级，标注为：929-01-2 带扁尾莫氏圆锥工作塞规 0#2 级，标注为：930-01-2

Order Description: Please mark name of the product,item No.and specifications for order.Please also mark the class. For example: Morse taper ring gauge with flat tail,0# class 2, mark with 929-01-2 and for Morse taper plug gauge with flat tail 0# class 2, mark with 930-01-2.



光滑极限塞规 933

Plain Limit Plug Gauges Type 933

- 光滑极限塞规是用来检测工件内孔的极限尺寸
- 符合 GB 标准
- The plain limit plug gauges are applied to measure the limit dimensions of inner holes of workpieces.
- It conforms to GB standard.



单位 (Unit) : mm

编号 Item No.	规格 Specifications	精度 Accuracy	质量 Weight(kg)
	1	H6;H7;H8;H9	0.0006
	1.05	H6;H7;H8;H9	0.0006
	1.1	H6;H7;H8;H9	0.0006
	1.15	H6;H7;H8;H9	0.0006
	1.2	H6;H7;H8;H9	0.0006
	1.25	H6;H7;H8;H9	0.0006
	1.3	H6;H7;H8;H9	0.0007
	1.4	H6;H7;H8;H9	0.0007
	1.5	H6;H7;H8;H9	0.0007
	1.6	H6;H7;H8;H9	0.0007
	1.7	H6;H7;H8;H9	0.0007
933	1.8	H6;H7;H8;H9	0.0008
	1.9	H6;H7;H8;H9	0.0008
	2	H6;H7;H8;H9	0.0008
	2.1	H6;H7;H8;H9	0.0008
	2.2	H6;H7;H8;H9	0.0009
	2.3	H6;H7;H8;H9	0.0009
	2.4	H6;H7;H8;H9	0.0009
	2.5	H6;H7;H8;H9	0.0009
	2.6	H6;H7;H8;H9	0.0010
	2.7	H6;H7;H8;H9	0.0010
	2.8	H6;H7;H8;H9	0.0010
	2.9	H6;H7;H8;H9	0.0011

单位 (Unit) : mm

编号 Item No.	规格 Specifications	精度 Accuracy	质量 Weight(kg)
	3	H6;H7;H8;H9	0.0011
	3.2	H6;H7;H8;H9	0.0025
	3.4	H6;H7;H8;H9	0.0026
	3.6	H6;H7;H8;H9	0.0027
	3.8	H6;H7;H8;H9	0.0028
	4	H6;H7;H8;H9	0.0029
	4.2	H6;H7;H8;H9	0.0030
	4.5	H6;H7;H8;H9	0.0032
	4.8	H6;H7;H8;H9	0.0034
	5	H6;H7;H8;H9	0.0036
	5.5	H6;H7;H8;H9	0.0040
933	6	H6;H7;H8;H9	0.0044
	6.5	H6;H7;H8;H9	0.0080
	7	H6;H7;H8;H9	0.0086
	7.5	H6;H7;H8;H9	0.0093
	8	H6;H7;H8;H9	0.0100
	8.5	H6;H7;H8;H9	0.0108
	9	H6;H7;H8;H9	0.0116
	9.5	H6;H7;H8;H9	0.0125
	10	H6;H7;H8;H9	0.0134
	10.5	H6;H7;H8;H9	0.0221
	11	H6;H7;H8;H9	0.0235
	11.5	H6;H7;H8;H9	0.0249



单位 (Unit) : mm

编号 Item No.	规格 Specifications	精度 Accuracy	质量 Weight(kg)
	12	H6;H7;H8;H9	0.0263
	12.5	H6;H7;H8;H9	0.0278
	13	H6;H7;H8;H9	0.0294
	13.5	H6;H7;H8;H9	0.0311
	14	H6;H7;H8;H9	0.0328
	14.5	H6;H7;H8;H9	0.0485
	15	H6;H7;H8;H9	0.0505
	15.5	H6;H7;H8;H9	0.0526
	16	H6;H7;H8;H9	0.0547
933	17	H6;H7;H8;H9	0.0592
	18	H6;H7;H8;H9	0.0680
	19	H6;H7;H8;H9	0.0830
	20	H6;H7;H8;H9	0.1090
	21	H6;H7;H8;H9	0.1280
	22	H6;H7;H8;H9	0.1470
	23	H6;H7;H8;H9	0.1580
	24	H6;H7;H8;H9	0.1660
	25	H6;H7;H8;H9	0.1970
	26	H6;H7;H8;H9	0.2080

单位 (Unit) : mm

编号 Item No.	规格 Specifications	精度 Accuracy	质量 Weight(kg)
	27	H6;H7;H8;H9	0.2510
	28	H6;H7;H8;H9	0.2660
	29	H6;H7;H8;H9	0.2780
	30	H6;H7;H8;H9	0.2870
	32	H6;H7;H8;H9	0.3020
	34	H6;H7;H8;H9	0.3130
	36	H6;H7;H8;H9	0.3260
	38	H6;H7;H8;H9	0.3680
	40	H6;H7;H8;H9	0.4780
933	42	H6;H7;H8;H9	0.5860
	45	H6;H7;H8;H9	0.6390
	48	H6;H7;H8;H9	0.8130
	50	H6;H7;H8;H9	1.1020
	60	H6;H7;H8;H9	1.4280
	70	H6;H7;H8;H9	2.0040
	80	H6;H7;H8;H9	2.9880
	90	H6;H7;H8;H9	3.2040
	100	H6;H7;H8;H9	3.8660

订货说明:

请按被测工件的直径及公差带等级订货。我厂可提供 H6、H7、H8、H9 级的光滑塞规。

例：工件内孔 26-H7，标注为：933-26H7。

Order instruction:

Please order by diameter and the tolerance zone of workpieces to be tested. We can provide plain limit gauges of H6, H7, H8, H9 classes.

For example:

inner hole 26 - H7 of workpiece, please specify 933-26H7.



对表环规 934

Plain Ring Gauges 934

- 对表环规是校准内径表及传递基准尺寸的量规
- 符合 Q/HLR 标准
- The plain ring gauges are used for calibrating dial bore gauges and transferring basic dimension.
- It conforms to Q/HLR standard.



单位 (Unit) : mm

编号 Item No.	d (mm) diameter	对表环规的极限偏差 Δd (μm) Limit deviation to the gauge Δd (μm)				
		1 级	2 级	3 级	4 级	5 级
934	$4 \leq d \leq 10$	± 0.2	± 0.4	± 0.8	± 1.25	± 1.5
	$10 \leq d \leq 30$	± 0.25	± 0.5	± 1.0	± 1.5	± 2.0
	$30 \leq d \leq 50$	± 0.3	± 0.6	± 1.25	± 2.0	± 2.5
	$50 \leq d \leq 80$	± 0.4	± 0.8	± 1.5	± 2.5	± 3.0
	$80 \leq d \leq 150$	± 0.6	± 1.25	± 2.5	± 3.0	± 5.0
	$150 \leq d \leq 200$	± 0.8	± 1.5	± 3.0	± 4.0	± 6.0
	$200 \leq d \leq 300$	± 1.0	± 2.0	± 4.0	± 6.0	± 8.0

订货说明: 按产品编号及规格订货。例: 934-20

Order instruction: Please Order by item number an specification. For example: 934-20



抽油泵螺纹量规 935 936

Thread Gauges For Oil Sucking Pumps 935 936

- 抽油泵螺纹量规适用于抽油泵及其组件规范
(GB/ T10607-2008) 中圆柱螺纹检测
- 符合 Q/HLR 标准
- The thread gauges are applied for checking cylindrical threads of oil sucking pumps and assembly to conform with GB/T18607-2008.
- It conforms to Q/HLR standard.



单位 (Unit) : inch

单位 (Unit) : inch

编号 Item No.	规格 Specifications	精度 Accuracy	质量 Weight(kg)		
			环规 Ring gauge	塞规 Plug gauge	
935	0.7500-10	3A; 3B	0.1726	0.0638	
	0.7500-16	3A; 3B	0.1082	0.0534	
	0.8750-14	3A; 3B	0.1758	0.0659	
	0.9375-16	3A; 3B	0.1460	0.0661	
	1.000-14	3A; 3B	0.2525	0.0778	
	1.1250-16	3A; 3B	0.2068	0.0864	
	1.1894-14	3A; 3B	0.2344	0.1291	
	1.2500-14	3A; 3B	0.2273	0.1362	
	936	1.3125-16	3A; 3B	0.2577	0.1381
		1.3330-16	3A; 3B	0.2554	0.1406
		1.3750-14	3A; 3B	0.2929	0.1520
		1.4704-14	3A; 3B	0.2797	0.1652
		1.5000-16	3A; 3B	0.2915	0.1618
		1.5084-14	3A; 3B	0.2743	0.1708
		1.5604-14	3A; 3B	0.2666	0.1786
		1.5730-16	3A; 3B	0.2266	0.1720
1.7500-14	3A; 3B	0.4104	0.2240		

编号 Item No.	规格 Specifications	精度 Accuracy	质量 Weight(kg)		
			环规 Ring gauge	塞规 Plug gauge	
935	1.8024-14	3A; 3B	0.4013	0.2338	
	1.8750-16	3A; 3B	0.3569	0.2356	
	1.9864-14	3A; 3B	0.5818	0.3244	
	2.0035-11 1/2	3A; 3B	0.6837	0.3493	
	2.0870-16	3A; 3B	0.5166	0.3341	
	2.1095-11 1/2	3A; 3B	0.6581	0.3779	
	2.2380-11 1/2	3A; 3B	0.6255	0.4149	
	2.3755-11 1/2	3A; 3B	0.8211	0.4571	
	936	2.5625-11 1/2	3A; 3B	0.7674	0.5452
		2.5730-16	3A; 3B	0.5950	0.5164
		2.7380-11 1/2	3A; 3B	0.7128	0.6331
		3.1715-11 1/2	3A; 3B	1.3123	0.8120
		3.1875-11 1/2	3A; 3B	1.3058	0.8188
		3.2380-11 1/2	3A; 3B	1.2848	0.8399
		3.3825-11 1/2	3A; 3B	1.2246	0.9046
		3.6875-11 1/2	3A; 3B	1.6829	1.0492
4.2380-11 1/2	3A; 3B	1.4058	1.3418		

订货说明: 请按产品编号规格及精度订货。例: 工件外螺纹 0.7500-10UNS-3A 用环规, 标注为: 935-0.7500-10UNS-3A

Order Description: Please order by item number, specification and accuracy.

E.g.: Ring gauge for measuring 0.7500-10UNS-3A external thread, specify 935-0.7500-10UNS-3A.



55°非密封管螺纹量规 937 938

Non-Sealing Pipe Threads With 55 Degree Thread Angle 937 938

- 55°非密封管螺纹量规适合检测
55°非密封管螺纹所规定螺纹制件
- 符合 GB 标准
- Pipe thread gauges are suitable for checking threaded workpieces 55 Degree Thread Angle Where Pressure-tight Joints Are Not Made on Threads.
- It conforms to GB standard.



单位 (Unit) : inch

编号 Item No.	规格 Specifications	质量 Weight(kg)	
		环规 Ring gauge	塞规 Plug gauge
937	G 1/16-28	0.0423	0.0058
	G 1/8-28	0.0409	0.0083
	G 1/4-19	0.0884	0.0166
	G 3/8-19	0.1213	0.0304
	G 1/2-14	0.2253	0.0615
938	G 5/8-14	0.2178	0.6840
	G 3/4-14	0.3103	0.0909
	G 7/8-14	0.2915	0.1105
	G 1-11	0.4762	0.1629
	G 1 1/8-11	0.4390	0.1969

单位 (Unit) : inch

编号 Item No.	规格 Specifications	质量 Weight(kg)	
		环规 Ring gauge	塞规 Plug gauge
937	G 1 1/4-11	0.6601	0.2305
	G 1 1/2-11	0.6001	0.2818
	G 1 3/4-11	0.8583	0.4603
	G 2-11	0.7822	0.5513
	G 2 1/4-11	0.9947	0.8792
938	G 2 1/2-11	1.0564	1.1365
	G 2 3/4-11	1.0895	1.3436
	G 3-11	1.4335	1.4488
	G 3 1/2-11	1.8693	1.5448
	G 4-11	1.5551	1.8369

订货说明: 请按产品的规格及精度订货。目前我厂通端量规提供平顶为 TB, 但是螺纹环规的止端分 A、B 级。

例: 工件外螺纹 G 1-11A 用环规, 标注为: 937-G1-11A

Order instruction: Please order by products specification and accuracy. At present, we can provide type TB flat top Go gauge. And there are A and B classes for No-Go thread ring gauge.

E.g.: Ring gauge for measuring G1-11A external thread, specify 937-G1-11A.



梯形螺纹量规 939 940

Trapezoidal Thread Gauges 939 940

- 梯形螺纹量规是用来检测牙形角度为 30°
- 用于机械传动和紧固件的梯形螺纹联接的螺纹量规
- Trapezoidal thread gauges are applied for checking 30°
- Degree trapezoidal teeth profile thread connection in mechanical transmission and of fasteners.



939 940

单位 (Unit) : mm

编号 Item No.	规格 Specifications	螺距 Thread pitch	质量 Weight(kg)	
			环规 Ring gauge	塞规 Plug gauge
939	Tr10	2	0.0844	0.0217
	Tr10	3	0.1101	0.0268
	Tr12	2	0.1070	0.0404
	Tr12	3	0.1577	0.0419
	Tr14	2	0.1032	0.0528
	Tr14	3	0.1523	0.0556
	Tr16	2	0.1456	0.0843
	Tr16	4	0.2846	0.0915
	Tr18	2	0.1405	0.1023
	940	Tr18	4	0.2755
940	Tr20	2	0.1347	0.1441
	Tr20	4	0.2651	0.1579
	Tr22	3	0.2899	0.1797
	Tr22	5	0.4689	0.1941
	Tr24	3	0.2797	0.2100
	Tr24	5	0.4534	0.2288
	Tr26	3	0.4087	0.2426
	Tr26	5	0.6593	0.2666

单位 (Unit) : mm

编号 Item No.	规格 Specifications	螺距 Thread pitch	质量 Weight(kg)	
			环规 Ring gauge	塞规 Plug gauge
939	Tr28	3	0.3965	0.2781
	Tr28	5	0.6417	0.3077
	Tr30	3	0.3833	0.3162
	Tr30	6	0.7875	0.3784
	Tr32	3	0.3691	0.4237
	Tr32	6	0.7608	0.4944
	Tr34	3	0.4836	0.4721
	Tr34	6	0.9913	0.5552
	Tr36	3	0.4675	0.5235
	940	Tr36	6	0.9606
940	Tr38	3	0.4505	0.5780
	Tr38	7	1.0568	0.7095
	Tr40	3	0.4325	0.6356
	Tr40	7	1.0184	0.7859
	Tr42	3	0.6775	0.7097
	Tr42	7	1.5736	0.8791
	Tr44	3	0.6576	0.7744
	Tr44	7	1.5309	0.9650



单位 (Unit) : mm

编号 Item No.	规格 Specifications	螺距 Thread pitch	质量 Weight(kg)	
			环规 Ring gauge	塞规 Plug gauge
	Tr46	3	0.6369	0.8426
	Tr46	8	1.7022	1.1001
	Tr48	3	0.6150	0.9135
	Tr48	8	1.6493	1.1970
	Tr50	3	0.5922	0.9875
	Tr50	8	1.5940	1.3046
	Tr52	3	0.9038	1.0881
	Tr52	8	2.3964	1.4373
939	Tr55	3	0.8663	1.2096
940	Tr55	9	2.5539	1.6614
	Tr60	3	0.7989	1.4276
	Tr60	9	2.3745	1.9855
	Tr65	4	1.3881	1.9545
	Tr65	10	3.2064	2.5035
	Tr70	4	1.2830	2.2521
	Tr70	10	2.9851	2.9108
	Tr75	4	1.6664	2.5724
	Tr75	10	3.8443	3.3504

单位 (Unit) : mm

编号 Item No.	规格 Specifications	螺距 Thread pitch	质量 Weight(kg)	
			环规 Ring gauge	塞规 Plug gauge
	Tr80	4	1.6341	2.9154
	Tr80	10	3.5873	3.8225
	Tr85	4	2.1751	3.2809
	Tr85	12	5.8291	4.7158
	Tr90	4	2.0298	3.6691
	Tr90	12	5.4606	5.3099
	Tr95	4	2.8992	4.0819
	Tr95	12	7.7088	5.9442
939	Tr100	4	2.7369	4.5155
940	Tr100	12	7.3137	6.5991
	Tr110	4	3.0569	1.6290
	Tr110	12	7.3286	3.6448
	Tr120	6	4.2533	2.5188
	Tr120	14	9.4278	4.7089
	Tr130	6	4.5401	2.8029
	Tr130	14	10.0724	5.2519
	Tr140	6	4.8269	3.0871
	Tr140	14	10.7171	5.7950

订货说明:

请按产品编号、规格、螺距及螺纹精度等级订货。我厂可提供 7h、8h、9h、7e、8e、9e、7c、8c、9c 级的环规和 7H、8H、9H 级的塞规。

例如：环规 Tr60×3-7c，标注为：939-Tr60×3-7c

塞规 Tr60×3-7H，标注为：940-Tr60×3-7H

Order instruction:

"Please order by item number specification, pitch and thread accuracy information. We can provide ring gauges of class 7h,8h,9h,7e,8e,9e,7c,8c and 9c as well as plug gauges of class 7H,8H and 9H."

E.g.: ring gauge Tr60×3-7c, please specify 939-Tr60×3-7c

Plug gauge Tr60×3-7H, please specify 940-Tr60×3-7H



抽油杆量规 941

Sucker Rod Gauge 941

- 抽油杆量规是用来检测抽油杆及其接箍的螺纹使用的螺纹量规
- 符合 SY 标准
- The sucker rod thread gauges are to check the sucker rods and corresponding connecting coupling threads.
- It conforms to SY standard.



单位 (Unit) : mm

编号 Item No.	公称直径 Nominal diameter	规格 Specifications	质量 Weight(kg)
941	12.7 (1/2)	P8-13	0.3410
	15.9 (5/8)	P8-16	0.4928
	19.1 (3/4)	P8-19	0.5391
	22.2 (7/8)	P8-22	0.8575
	25.4 (1)	P8-25	1.2142
	28.6 (1 1/8)	P8-29	1.2538
	12.7 (1/2)	P6-13	0.1645
	15.9 (5/8)	P6-16	0.2642
	19.1 (3/4)	P6-19	0.2692
	22.2 (7/8)	P6-22	0.4017
	25.4 (1)	P6-25	0.4981
	28.6 (1 1/8)	P6-29	0.5108
	12.7 (1/2)	B1-13	0.3410
	15.9 (5/8)	B1-16	0.4928
	19.1 (3/4)	B1-19	0.5391
	22.2 (7/8)	B1-22	0.8575
	25.4 (1)	B1-25	1.2142
	28.6 (1 1/8)	B1-29	1.2538
	12.7 (1/2)	B5-13	0.1645
	15.9 (5/8)	B5-16	0.2642

单位 (Unit) : mm

编号 Item No.	公称直径 Nominal diameter	规格 Specifications	质量 Weight(kg)
941	19.1 (3/4)	B5-19	0.2692
	22.2 (7/8)	B5-22	0.4017
	25.4 (1)	B5-25	0.4981
	28.6 (1 1/8)	B5-29	0.5108
	15.9 (5/8)	P4-16	0.4928
	19.1 (3/4)	P4-19	0.5391
	22.2 (7/8)	P4-22	0.8575
	25.4 (1)	P4-25	1.2142
	28.6 (1 1/8)	P4-29	1.2538
	15.9 (5/8)	B3-16	0.4928
	19.1 (3/4)	B3-19	0.5391
	22.2 (7/8)	B3-22	0.8575
	25.4 (1)	B3-25	1.2142
	28.6 (1 1/8)	B3-29	1.2538
	12.7 (1/2)	P2-13	0.3410
	15.9 (5/8)	P2-16	0.4928
19.1 (3/4)	P2-19	0.5391	
22.2 (7/8)	P2-22	0.8575	
25.4 (1)	P2-25	1.2142	
28.6 (1 1/8)	P2-29	1.2538	

订货说明: 请按照产品的编号及规格订货。例: 941-P8-13

Order Description: Please specify item number and specification in your order, e.g.: 941-P8-13



抽油杆量规 942

Sucker Rod Gauge 942

- 抽油杆量规是用来检测抽油杆及其接箍的螺纹使用的螺纹量规
- 符合 SY 标准
- The sucker rod thread gauges are to check the sucker rods and corresponding connecting coupling threads.
- It conforms to SY standard.



单位 (Unit) : mm

编号 Item No.	公称直径 Nominal diameter	规格 Specifications	质量 Weight(kg)
942	12.7 (1/2)	P7-13	0.1440
	15.9 (5/8)	P7-16	0.2250
	19.1 (3/4)	P7-19	0.3150
	22.2 (7/8)	P7-22	0.4290
	25.4 (1)	P7-25	0.6700
	28.6 (1 1/8)	P7-29	0.9530
	12.7 (1/2)	P5-13	0.0904
	15.9 (5/8)	P5-16	0.1460
	19.1 (3/4)	P5-19	0.1857
	22.2 (7/8)	P5-22	0.2375
	25.4 (1)	P5-25	0.3435
	28.6 (1 1/8)	P5-29	0.4861
	12.7 (1/2)	B2-13	0.1018
	15.9 (5/8)	B2-16	0.1538
	19.1 (3/4)	B2-19	0.2097
	22.2 (7/8)	B2-22	0.2775
	25.4 (1)	B2-25	0.4338
	28.6 (1 1/8)	B2-29	0.6143
	12.7 (1/2)	B6-13	0.0565
	15.9 (5/8)	B6-16	0.0814

单位 (Unit) : mm

编号 Item No.	公称直径 Nominal diameter	规格 Specifications	质量 Weight(kg)
942	19.1 (3/4)	B6-19	0.9640
	22.2 (7/8)	B6-22	0.1296
	25.4 (1)	B6-25	0.1961
	28.6 (1 1/8)	B6-29	0.2654
	15.9 (5/8)	P3-16	0.1538
	19.1 (3/4)	P3-19	0.2097
	22.2 (7/8)	P3-22	0.2775
	25.4 (1)	P3-25	0.4338
	28.6 (1 1/8)	P3-29	0.6143
	15.9 (5/8)	B4-16	0.1538
	19.1 (3/4)	B4-19	0.2097
	22.2 (7/8)	B4-22	0.2775
	25.4 (1)	B4-25	0.4338
	28.6 (1 1/8)	B4-29	0.6143
	12.7 (1/2)	P1-13	0.1440
	15.9 (5/8)	P1-16	0.2250
	19.1 (3/4)	P1-19	0.3150
	22.2 (7/8)	P1-22	0.4290
	25.4 (1)	P1-25	0.6700
	28.6 (1 1/8)	P1-29	0.9530

订货说明：请按照产品的编号及规格订货。例：942-P7-13

Order Description: Please specify item number and specification in your order. e.g.: 942-P7-13



60°锥管螺纹量规 943 944

60° Taper Pipe Thread Gauges 943 944

- 60°锥管螺纹量规适用于检验 (GB/T12716) 所规定 NPT 螺纹
- 60°Taper pipe thread gauges are applicable for checking and examining NPT thread stipulated in GB/T12716.



单位 (Unit) : inch

编号 Item No.	规格 Specifications	质量 Weight(kg)
943	NPT 1/8-27	0.0295
	NPT 1/4-18	0.0584
	NPT 3/8-18	0.0837
	NPT 1/2-14	0.1519
	NPT 3/4-14	0.2195
	NPT 1-11.5	0.3176
	NPT 1 1/4-11.5	0.4569
	NPT 1 1/2-11.5	0.4164
	NPT 2-11.5	0.5573

单位 (Unit) : inch

编号 Item No.	规格 Specifications	质量 Weight(kg)
944	NPT 1/8-27	0.0083
	NPT 1/4-18	0.0198
	NPT 3/8-18	0.0346
	NPT 1/2-14	0.0693
	NPT 3/4-14	0.0973
	NPT 1-11.5	0.1830
	NPT 1 1/4-11.5	0.2780
	NPT 1 1/2-11.5	0.3470
	NPT 2-11.5	0.5990

订货说明: 请按照产品编号及规格订货。

例: 环规 943-NPT-1/8-27 塞规 944-NPT-1/8-27

Order Description: Please specify item number and specification in order.

e.g.: ring gauge 943-NPT-1/8-27, plug gauge 944-NPT-1/8-27.



用螺纹密封的管螺纹量规 945 946

Gauges For Pipe Threads Where Pressure-Tight Joints Are Made On The Threads 945 946

- 用螺纹密封的管螺纹量规适用于检验 (GB/T7306) 所规定的圆锥螺纹和圆柱螺纹尺寸
- Gauges for pipe threads where pressure-tight joints are made on the threads are applicable for checking and examining dimensions of taper screw threads and parallel screw threads stipulated in GB/T7306.



945 | 946

单位 (Unit) : inch

编号 Item No.	规格 Specifications	质量 Weight(kg)
945	R 1/8-28	0.0287
	R 1/4-19	0.06237
	R 3/8-19	0.0856
	R 1/2-14	0.1517
	R 3/4-14	0.2372
	R 1-11	0.3230
	R 1 1/4-11	0.5285
	R 1 1/2-11	0.4822
	R 2-11	0.7611

单位 (Unit) : inch

编号 Item No.	规格 Specifications	质量 Weight(kg)
946	Rc 1/8-28	0.0083
	Rc 1/4-19	0.0198
	Rc 3/8-19	0.0346
	Rc 1/2-14	0.0693
	Rc 3/4-14	0.0973
	Rc 1-11	0.1830
	Rc 1 1/4-11	0.2780
	Rc 1 1/2-11	0.3470
	Rc 2-11	0.5990

订货说明: 请按照产品编号及规格订货。

例: 环规 945-R-1/8-28 塞规 946-Rc-1/8-28

Order Description: Please specify item number and specification in order.

e.g.: ring gauge 945-R-1/8-28, plug gauge 946-Rc-1/8-28.



气瓶专用螺纹量规 947 948

Special Thread Gauge For Gas Cylinders 947 948

- 用于检验 BG8335 气瓶专用螺纹中规定的圆锥螺纹及圆柱螺纹
- Used for checking taper thread and cylinder thread specified in special thread of BG8335 gas cylinder.



单位 (Unit) : mm

编号 Item No.	规格 Specifications	牙数 / 英寸 Tooth / inch	螺距 Thread pitch	锥度值 Taper	质量 Weight(kg)	
					环规 Ring gauge	塞规 Plug gauge
947	PZ39.0	12	2.117	3:25	0.2150	0.1815
	PZ30.3	14	1.814	3:25	0.1600	0.1371
948	PZ27.8	14	1.814	3:25	0.1408	0.0828
	PZ19.2	14	1.814	3:25	0.1103	0.0580

订货说明：气瓶专用量规我厂可提供螺纹量规及光面量规。

例：气瓶专用螺纹环规 PZ39.0，标注为：947-PZ39.0- 螺纹

Order Description: we can supply thread gauge and plain gauge regarding special gauge for gas cylinder.

Please specify when orders:

E.g.: thread ring gauge for gas cylinder PZ39.0

Specify 947-PZ39.0-thread



美制干密封管螺纹量规 949 950

US-System Dry Seal Pipe Thread Gauge 949 950

- 符合 ASME B1.20.5 标准

- Conform to standard ASME B1.20.5



949 950

单位 (Unit) : mm

编号 Item No.	规格 Specifications	螺距 Thread pitch	锥度值 Taper	质量 Weight(kg)	
				环规 Ring gauge	塞规 Plug gauge
949	1/16-27NPTF	0.941	1:16	0.0198	0.0048
	1/8-27NPTF	0.941	1:16	0.0287	0.0083
	1/4-18NPTF	1.411	1:16	0.0624	0.0198
	3/8-18NPTF	1.411	1:16	0.0856	0.0346
	1/2-14NPTF	1.814	1:16	0.1517	0.0693
	3/4-14NPTF	1.814	1:16	0.2372	0.0973
950	1-11.5 NPTF	2.209	1:16	0.3230	0.1830
	1 1/4-11.5NPTF	2.209	1:16	0.4822	0.2780
	1 1/2-11.5NPTF	2.209	1:16	0.5285	0.3470
	2-11.5NPTF	2.209	1:16	0.7611	0.5990
	2 1/2-8 NPTF	3.175	1:16	0.9864	0.8789
	3-8 NPTF	3.175	1:16	1.2380	1.2043

订货说明: 请按产品编码、规格及用途订货。我厂可提供 L1、L2 螺纹环规及光面环规; L1、L3 螺纹塞规及光面塞规。

例: 美制干密封螺纹环规 2-11.5NPTF, 用途为 L1, 标注为: 949-2-11.5NPTF-L1

Order Description: please specify item no., type and application when orders. We can supply L1 and L2 thread ring gauge, plain ring gauge, L1 and L3 thread plug gauge, plain plug gauge.

E.g.: US-system dry seal pipe thread gauge 2-11.5NPTF, used for L1. specify 949-2-11.5NPTF-L1



组合式表面粗糙度比较样块 951

Multi-Pattern Surface Roughness Comparison Specimens 951

- 组合式表面粗糙度比较样块是用比较法检查零件表面粗糙度的一种量具，在机械工业生产中得到广泛的应用
- 符合 GB 标准
- The surface roughness comparison specimens are used to check the surface roughness of workpieces by comparison.They are widely used in machinery industry.
- It conforms to GB standard.

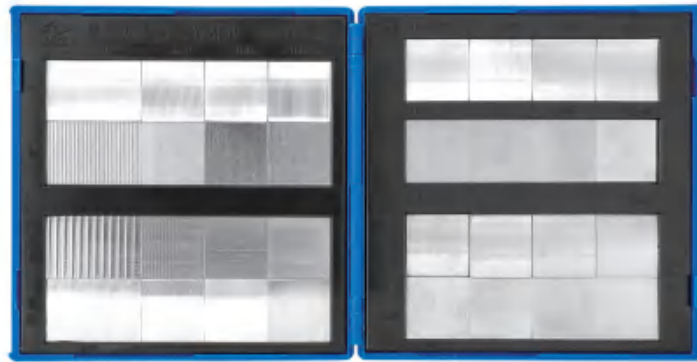

单位 (Unit) : μm

编号 Item No.	组别 Sets	Ra										质量 Weight(kg)
		6.30	3.20	1.60	0.80	0.40	0.20	0.10	0.05	0.025	0.012	
951-01	车 Turning	●	●	●	●							0.142
	镗 Boring	●	●	●	●							
	刨 Planing	●	●	●	●							
	平铣 Plain milling	●	●	●	●							
	端铣 End milling	●	●	●	●							
	磨外圆 Cylindrical grinding				●	●	●	●				
	平磨 Plane grinding				●	●	●	●				
	研磨 Lapping							●	●	●	●	



单组合式表面粗糙度比较样块 952

Single-Pattern Surface Roughness Comparison Specimens 952



单位 (Unit) : μm

编号 Item No.	组别 Sets	Ra										质量 Weight(kg)	
		6.30	3.20	1.60	0.80	0.40	0.20	0.10	0.05	0.025	0.012		
952-01	平铣 Plain milling	●	●	●	●								
952-02	端铣 End milling	●	●	●	●								
952-03	刨 Planing	●	●	●	●								
952-04	车外圆 Turning	●	●	●	●								
952-05	锉 Filing	●	●	●	●								
952-06	镗 Boring	●	●	●	●								0.046
952-07	磨内孔 Internal grinding				●	●	●	●					
952-08	抛光 Polishing				●	●	●	●					
952-09	磨外圆 Cylindrical grinding				●	●	●	●					
952-10	平磨 Plane grinding				●	●	●	●					
952-12	手研 Hand Lapping							●	●	●	●		



